



Scan this QR Code for more information



**GREENTECH** Diaphragms Standard. Buna-N Optional.

ZETA 100 low pressure 3-cylinder diaphragm pumps have anodized aluminum bodies with plasticized aluminum heads, stainless steel valves and glass-filled nylon manifolds. A pulsation dampener standard on all models.

ZETA 100 pumps are excellent for various horticultural and agricultural spraying applications.



ZETA 100 1C

ZETA 100 VA

ZETA 100 TS1C

ZETA 100 MI1

Model	GPM	l/min	PSI	bar	RPM	Drive Configuration	Weight
ZETA 100 1C	26.0	98	300	20	550	1-3/8" 6-Spline Male PTO Shaft	30 LBS
ZETA 100 VA	26.0	98	300	20	550	Universal VA Drive Face.	30 LBS
ZETA 100 TS1C	26.0	98	300	20	550	1-3/8" 6-Spline Male PTO x 25mm Solid Keyed Thru-Shaft	30 LBS
ZETA 100 MI1	26.0	98	300	20	550	2-Bolt, A-Flange, 1" Hollow Shaft for Hydraulic Motor	30 LBS

**Specifications**

**ZETA 100**

Inlet Port	1-1/2" Hose Barb
Outlet Port	3/4" Hose Barb
Piston Diameter	65.0mm
Crankshaft Stroke/Code	18.0mm / A
Dimensions	13"L x 11"W x 12"H

**Lubrication:** Requires 39 oz. of Udor Lube 40W Premium Pump Oil.  
Alternate Oil: 30W non-detergent or 15W-40 non-detergent oil.

**QUICK REFERENCE SERVICE PARTS**

Description	Part #
Diaphragm Kit - GREENTECH	8700.10
Diaphragm Bolt & Washer Kit	6062.48
Valve Kit	6062.D8
Complete Repair Kit	8700.61CK

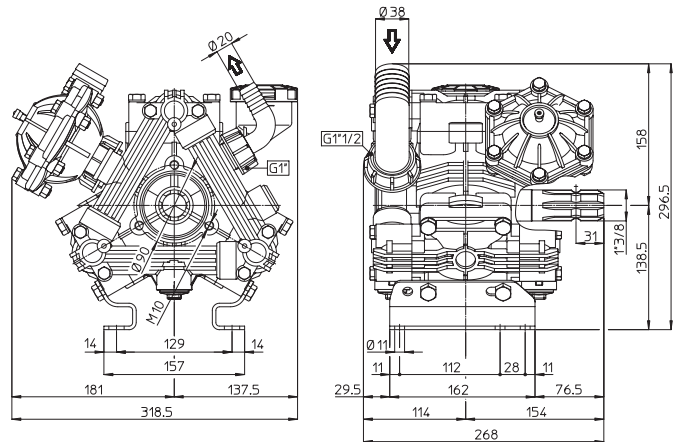

Dimensional Drawings are Shown in Millimeters.  
To Convert to Inches, Multiply Dimension x 0.03937

**Recommended Accessories and Drive Options**



**6005.31/LP**  
Control Unit  
Regulator



**6005.31/LP-N**  
Control Unit  
Regulator - NPT



**6066.05**  
PTO Drive  
Safety Shield



**UD1-1/2-16**  
1-1/2" HI-Flow Filter  
16 Mesh Screen



**15.5823**  
Udor Lube  
Premium Pump Oil

# ZETA 100 DIMENSIONS

All Dimensions are WITHOUT Control Unit or Regulator

Dimensional Drawings are Shown in Millimeters. To Convert to Inches, Multiply Dimension x 0.03937

## Specifications

## ZETA 100

Inlet Port - Hose Barb	1-1/4" HB
Outlet Port - Hose Barb	3/4" HB
Dimensions	10.5" L x 10" W x 9" H
Diaphragm Material	GREENTECH (Std) Buna-N (Opt)

**Lubrication:** Requires 39 oz. of Udor Lube 40W Premium Pump Oil. Alternate Oil: 30W non-detergent or 15W-40 non-detergent oil.

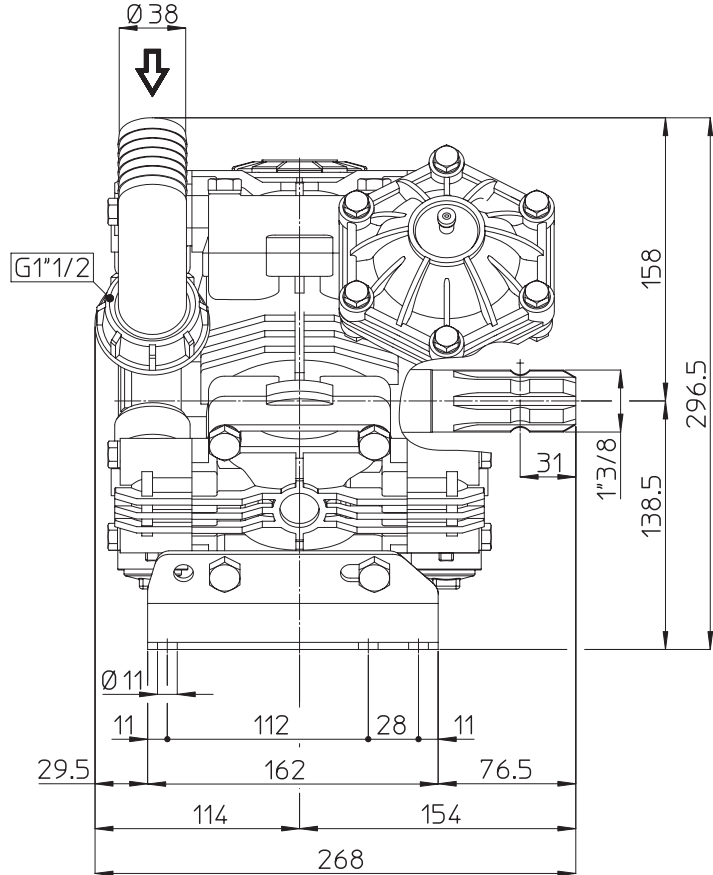
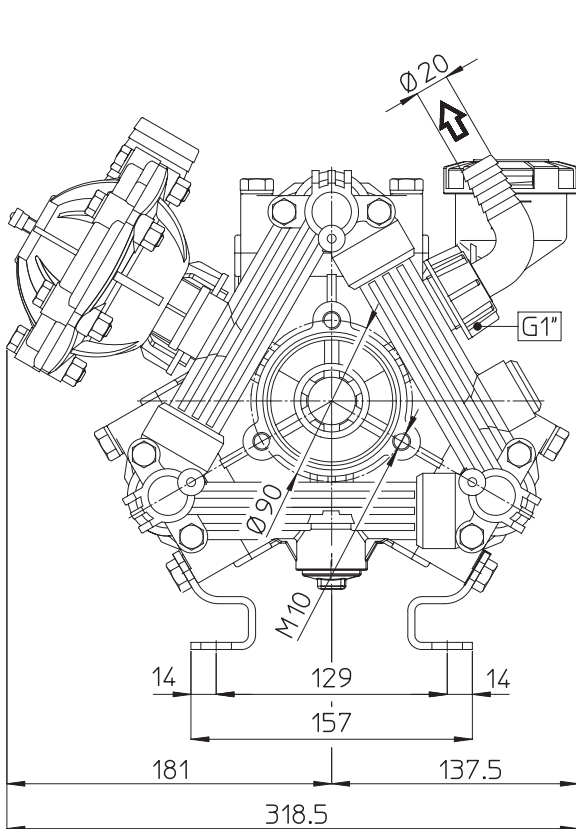

## TORQUE SPECS

Ref.	Description	Ft./lb.	Nm
1	Diaphragm Bolts (Use Loctite 243)	18	25
2	Head Bolts	30	40
3	Pulsation Dampener Bolts	18	25
4	Oil Cup Bolts	6	8
5	Manifold Bolts (Plastic)	14	20

