



Ultra Air Pump

UPR

Air-hydraulic pump, remote controlled operation, ergonomic push-button panel, pneumatic connection length 3m, oil flow (l / min) 0,8 / 0,14 (1000bar) - 1,1 / 0,15 (l / min) a (700bar)) - 2.1 / 0.2 (500bar) - 2.5 / 0.25 (400bar) - 2.6 / 0.7 (250bar)

Series: UP

Product line: Industrial tools, bodywork, car repairers, lifting systems

- Pneumatic piston drive with brass pins
- Pneumatic operation through a 2 or 3 button remote control (safety/emergency)
- Ergonomic handle for easy transport
- Pneumatic connection to the push-button panel standard length 3m (can be supplied to measure)
- Protective case
- Single acting cylinder compatibility
- Compact and sturdy construction for heavy duty long durability
- No air lubricated required
- It works through the normal pneumatic network
- Versatile use in both horizontal and vertical positions
- Venting screw on the cover to avoid any air overpressure inside the oil tank during the operations
- Preset safety valve on the cover to protect the pump
- Maximum oil pressure valve adjustable from the outside to protect the hydraulic circuit parts
- Removable pyrex oil level indicator for easy refill and relief valve adjustments
- Slots on the base support for easy installation fix on the system
- Lightweight
- Low noise (75dBa)
- Oversize oil tanks available (2,4 – 5 – 10 – 20) L for small and bigger cylinders

Technical features:

Max working pressure (bar):	250	400	500	700	1000	
Cylinder compatibility:	Single effect Double effect through hand valve (optional)					
Oil tank capacity (L):	2,4 – 5 – 7 – 10 – 12 – 20					
Usabel oil (L):	2,1 – 4,65 – 6,9 – 9,5 – 11,1 – 19,4					
Max oil flow nominal (l/min):	0,7	0,25	0,2	0,15	0,14	
Oil flow without load (l/min):	2,6	2,5	2,1	1,1	0,8	
Oil flow with load (l/min):	0,7	0,25	0,2	0,15	0,14	
Oil port:	3/8"NPTF (G3/8" – G1/4")					
Air port:	G1/4"					
Valve operation:	Advance/Hold/Release					
Power source:	Manuale					
Pneumatic range (bar):	Aria					
Average air consumption (l/min):	2,8/8,3 (10 max)					
Noise (dBA):	390		320	400	400	
Weight (Kg):	75					
Cylinder compatibility:	7,8					

Size:

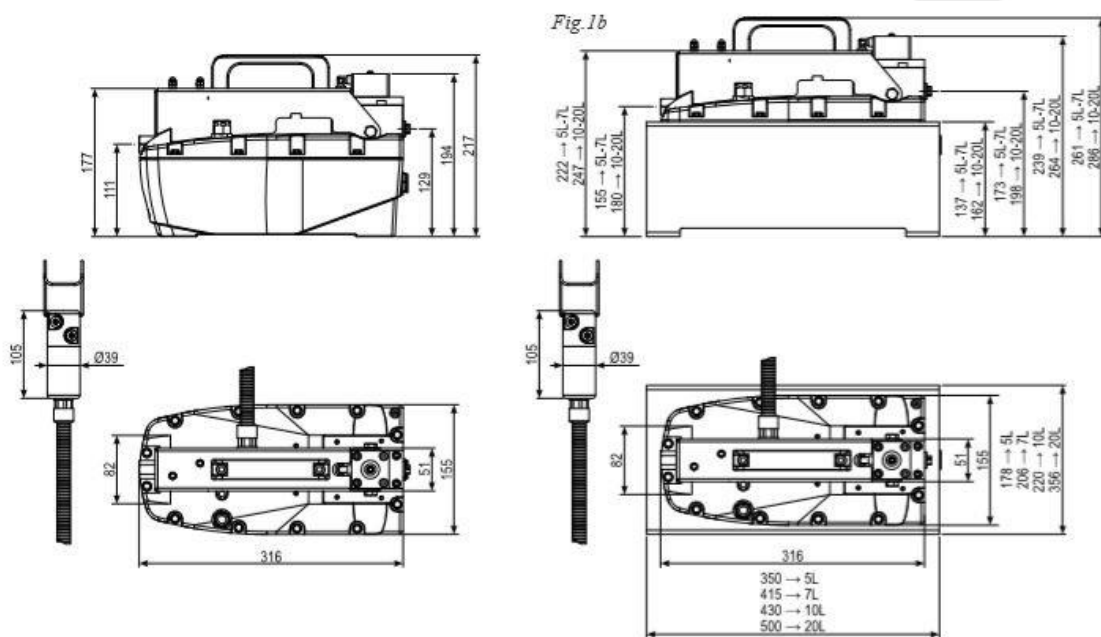

Series comparison:

Type	Max pressure (bar)	Cylinder	Tank (L)	Usable oil (L)	Oil flow unload (l/min)	Oil flow load (l/min)	Air range (bar)	Air consump (l/min)	Weight (kg)
UPR1002	1000	S.E.	2,4	2,1	0,8	0,14	2,8/10		7,8
UPR702	700	S.E.	2,4	2,1	1,1	0,15	2,8/10	50/440	7,8
UPR502	500	S.E.	2,4	2,1	2,1	0,2	2,8/10	110/320	7,8
UPR402	400	S.E.	2,4	2,1	2,5	0,25	2,8/10		7,8
UPR252	250	S.E.	2,4	2,1	2,6	0,7	2,8/10	180/390	7,8

To order:

- P/N 915250440 UPR1002 1000BAR BELL
- P/N 915250190 UPR702 700BAR BELL
- P/N 915250220 UPR502 500BAR BELL
- P/N 91520098X UPR402 400BAR BELL
- P/N 915250010 UPR252 250BAR BELL

Accessories:

- Oversize oil tanks
- Fixing plates
- Fitting
- Hose flex
- 3 button remote control (advance/release/safety)
- In line hand valve

Spare parts:

- SEAL KIT UPR