

TECHNICAL DETAILS

NOMINAL PRESSURE :
 WORKING PRESSURE :
 WHEN EXTRACTING : 6 bar
 WHEN RETRACTING : 6 bar
 TEST PRESSURE : 10 bar
 TEST PROCEDURE : 10-03-T03
 AMBIANT TEMPERATURE : -20 - +80 °C
 USED FLUID : AIR
 SPEED : max.1 m/sec.
 CUSHIONING : BOTH ENDS

SEALS MATERIALS : NBR, PU
 CYLINDER INSIDE DIAMETER : Ø50
 ROD DIAMETER : Ø20
 STROKE : 100
 PAINTING PROCEDURE : 09-02-T11
 MARKING PROCEDURE : 15-01-T10
 PACKAGING PROCEDURE : 15-01-T10
 NOTE: Piston Rod material AISI 304

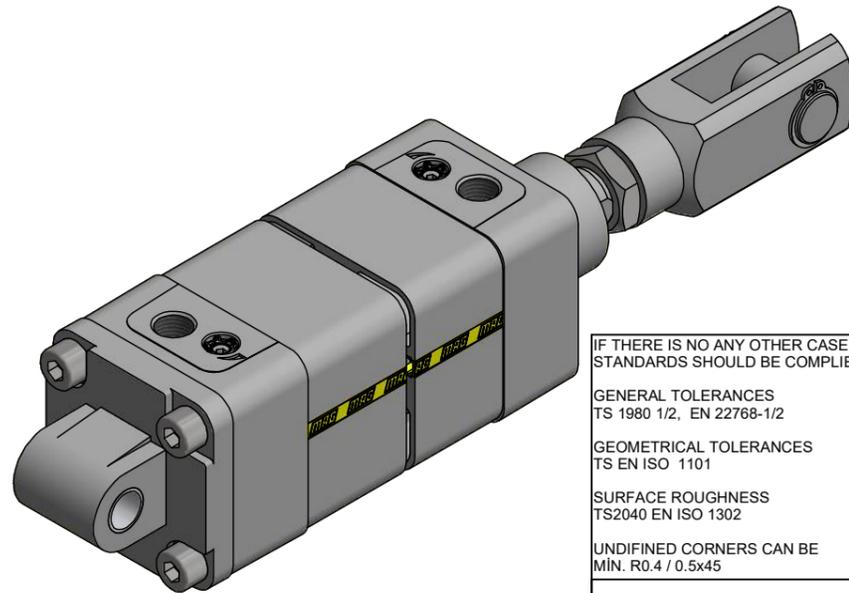

IF THERE IS NO ANY OTHER CASE BELOW STANDARDS SHOULD BE COMPLIED

GENERAL TOLERANCES
 TS 1980 1/2, EN 22768-1/2

GEOMETRICAL TOLERANCES
 TS EN ISO 1101

SURFACE ROUGHNESS
 TS2040 EN ISO 1302

UNDEFINED CORNERS CAN BE
 MIN. R0.4 / 0.5x45

GENERAL TOLERANCES					
0 ≤ < 6	6 ≤ < 30	30 ≤ < 120	120 ≤ < 315	315 ≤ < 1000	1000 ≤ < 2000
± 0.1	± 0.2	± 0.3	± 0.5	± 0.8	± 1.2

TS ISO 5456-1

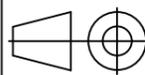

ALL RIGHTS RESERVED BY MERT AKISKAN GUCU SAN VE TIC A.S.
 COPYING, REPRODUCING, USING BY THIRD PARTY BOUNDED
 WITH THE PRIOR WRITTEN PERMISSION.

	DATE	NAME	SIGN
PROJECT	28.04.2017	H.KARAÇAM	
DRAWN	28.04.2017	A.AYBEK	
CONTROL	28.04.2017	H.KARAÇAM	
SCALE	MATERIAL	WEIGHT	QTY
.	.	-	.



**MERT AKIŞKAN GÜCÜ
 SAN.ve TİC.A.Ş.**

CUSTOMER DRAWING NR.	ORDER CODE	REVISION
.	.	0
PART NAME	DRAWING NR.	
PNEUMATIC CYLINDER	IS-50x100+CB+EBX	