

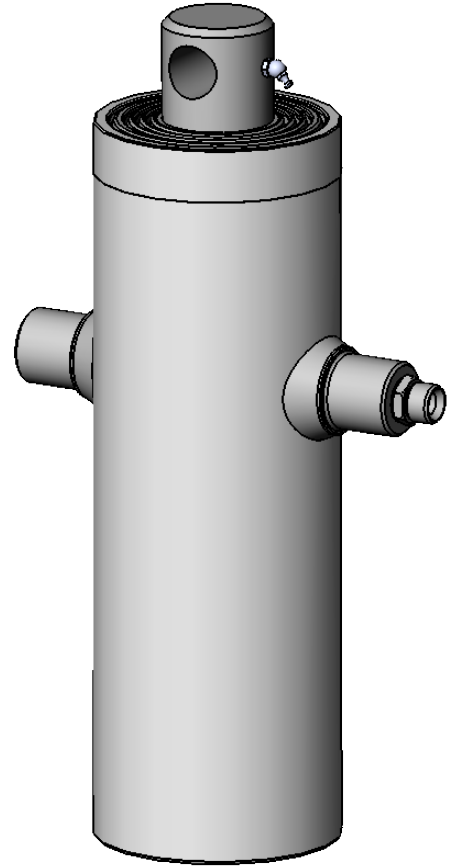
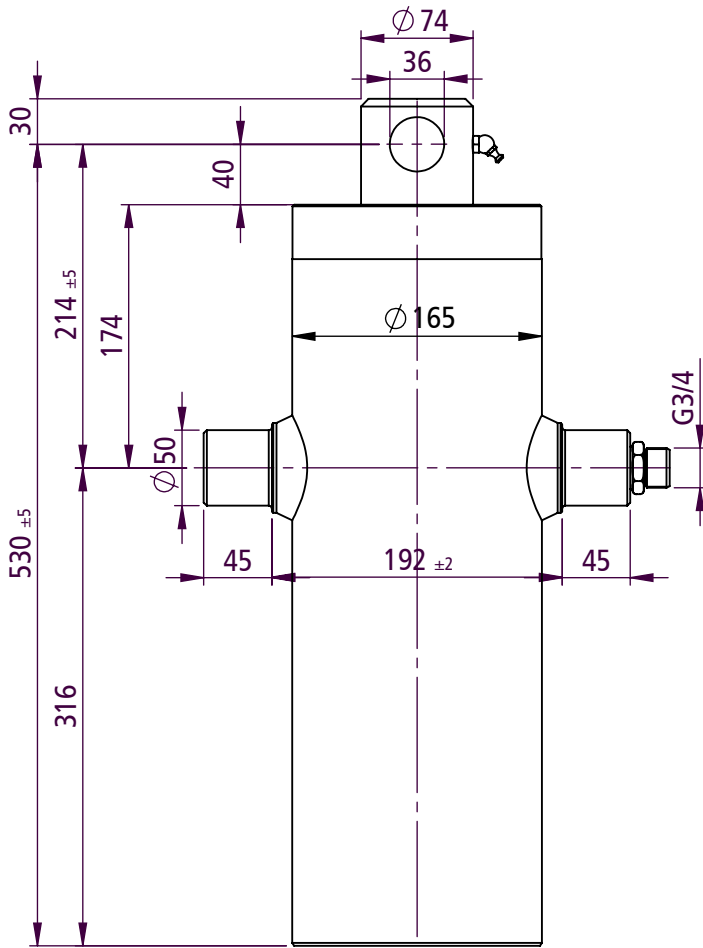

**Light duty cylinder, eye - pins**

Part Number

**3104451404001**

Tipping weight

**15-25 ton**

<b>mounting dimension</b>		<b>214 mm + 20 mm min pull out</b>				<b>total stroke</b>		<b>1505 mm</b>		<b>max pressure</b>		<b>180 bar</b>			
<b>model: BL445 1505 140 4</b>				<b>code: 3104451404001</b>				<b>weight: 57 kg</b>				<b>HS Penta</b>			
<b>extension</b>	1	2	3	4	-	-	-	-	-	--	--	<b>number of stages: 4</b>			
<b>diameter [mm]</b>	140	120	105	90	--	--	--	--	--	--	--				
<b>stroke [mm]</b>	379	376	381	369	--	--	--	--	--	--	--	<b>total: 1505 mm</b>			
<b>thrust [kN]</b>	277	204	156	115	--	--	--	--	--	--	--	<b>max thrust admitted: 148 kN</b>			
<b>oil [dm³]</b>	5.8	4.3	3.3	2.3	--	--	--	--	--	--	--	<b>total: 15.7 dm³</b>			

### TECHNICAL NOTES AND SPECIFICATIONS

- The normal application of telescopic cylinder is to lift up tipping bodies, loaded with different materials, and consequently discharge this material whilst the cylinder is extended all along its stroke.
- The body weight plus the max payload are the max tipping weight that can be raised by the cylinder. This value, calculated at the max pressure, is a rough indication of the tipping power of the cylinder and must be used as a first criteria for the selection of the cylinder. The real tipping mass can only be calculated by the design engineer of the dump truck, and must take into account the geometry of the dump body and operating conditions. Never exceed the maximum thrust.
- Never exceed maximum pressure.
- The cylinder has been designed for loads along the longitudinal axis: the cylinder is a lifting device only and may not be used as structural member or be subject to side load.
- The ordinary use of telescopic cylinder does not require any coating as the telescopic stages are exposed to atmospheric agents only during the tip-up operation. Therefore telescopic cylinders will be supplied without any coating in absence of any specific requirements.
- H.S.PENTA warranty does not apply to any kind of corrosion of coated or non-coated parts. See terms of warranty.
- Maximum extension speed less than 0.2 m/s.
- Hydraulic oil temperature admitted between -40°C and +100°C.
- In case the cylinders must be stored, do not remove the package. Store them in a dry place, not exposed to rain. Do not store the cylinders for more than 6 (six) months.
- Further specifications see mounting instructions, hydraulic oil specification sheet, user & maintenance manual.

#### REMARKS

[2012.07.24] [2017.05.09]

#### REVISIONS

	01
	02
	03
	04