

Scambiatore tipo SS10 Serie Aria-Olio Heat exchanger series SS10 Air-Oil version



CARATTERISTICHE TECNICHE DEL GRUPPO DI VENTILAZIONE TECHNICAL FEATURES

Tipologia Type	Frequenza Frequency Hz	Tensione Voltage V	N° Giri/min RPM	Potenza Power kW	Diam. Ventola Ø FAN (mm)	dB (A)	L (mm)	Q air (m³/h)	Cap. (lt)	Peso Weight (kg)	IP
01	50/60	230	2650/3000	0.050/0.046	170	63	125	500	0.28	6	44
03	50/60	400	2750/3100	0.045/0.043	170	63	125	500	0.28	6	44
12	DC	12	4000	0.080	167	64	158	550	0.28	5	65
24	DC	24	4100	0.080	167	64	158	550	0.28	5	65

Portata olio consigliata da 5 a 40 (lt/min)
Suggested oil flow from 5 to 40 (lt/min)

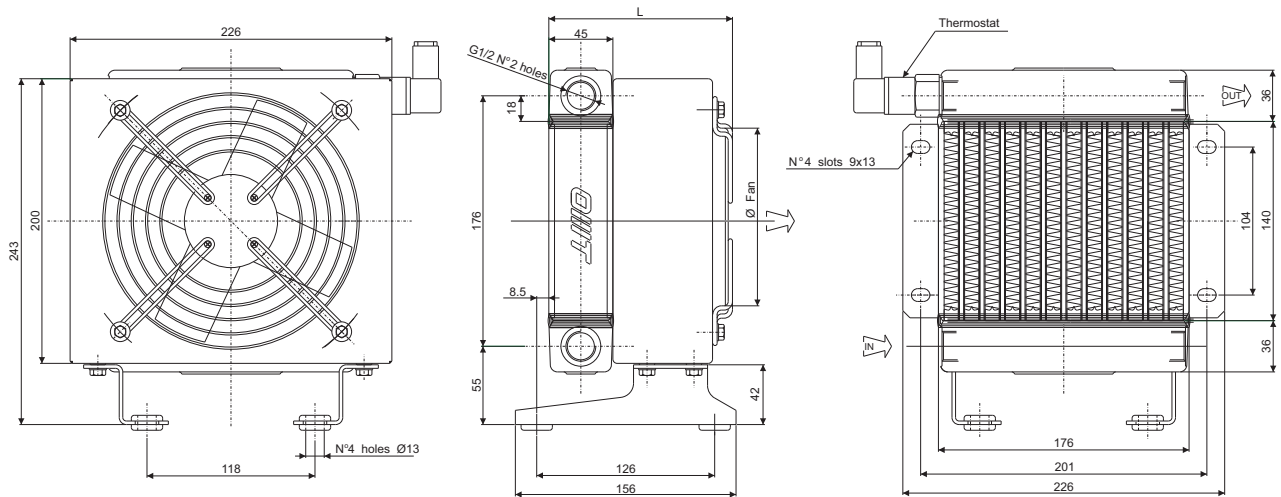

Coefficiente di correzione Correction factor

CST	10	15	20	32	40	50	60	80	100	200
F	0.51	0.66	0.76	1	1.22	1.4	1.6	1.9	2.1	3.4

Diagramma di rendimento Performance diagram



Diagramma perdite di carico (32 cst) Pressure drop diagram (32 cst)



Scambiatore tipo SS15 Serie Aria-Olio Heat exchanger series SS15 Air-Oil version

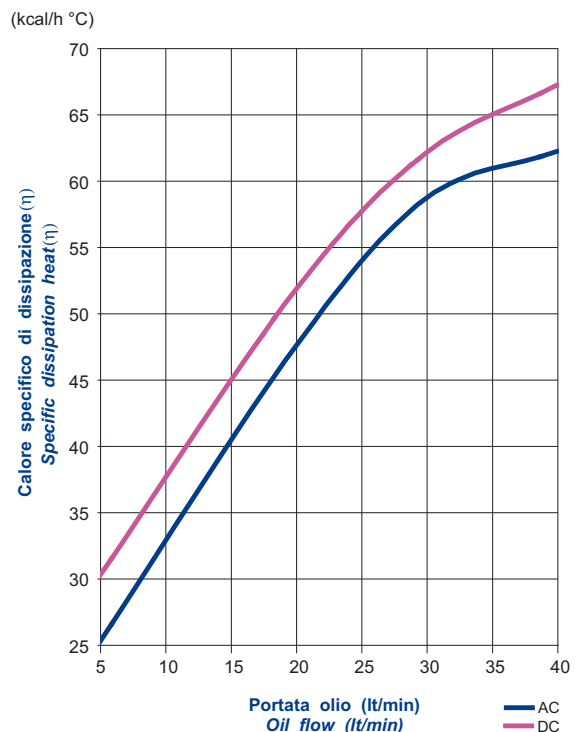
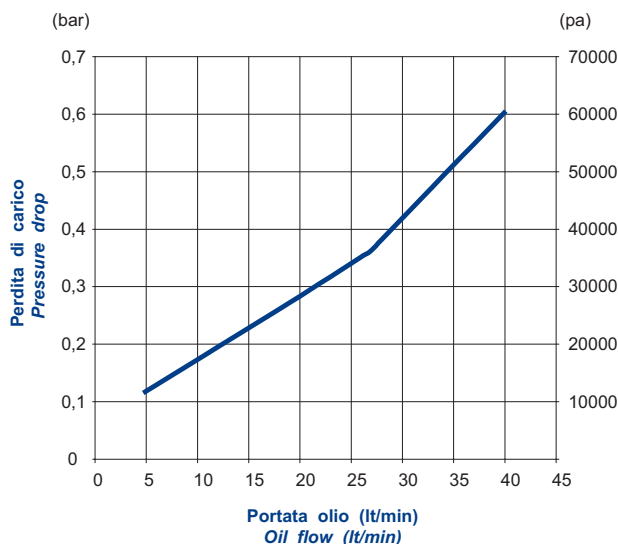

CARATTERISTICHE TECNICHE DEL GRUPPO DI VENTILAZIONE TECHNICAL FEATURES

Tipologia Type	Frequenza Frequency Hz	Tensione Voltage V	N° Giri/min RPM	Potenza Power kW	Diam. Ventola Ø FAN (mm)	dB (A)	L (mm)	Q air (m³/h)	Cap. (lt)	Peso Weight (kg)	IP
01	50/60	230	2600/2900	0.064/0.078	200	67	152	890	0.48	7	44
03	50/60	400	2600/2900	0.068/0.070	200	67	152	890	0.48	7	44
14	50/60	230/400	1370/1650	0.25	200	67	346	700	0.48	10	55
12	DC	12	3100	0.100	225	66	158	1200	0.48	6.5	65
24	DC	24	3000	0.100	225	66	158	1200	0.48	6.5	65
G2	-	-	-	-	200	-	-	-	-	6	-

Portata olio consigliata da 20 a 80 (lt/min)
Suggested oil flow from 20 to 80 (lt/min)

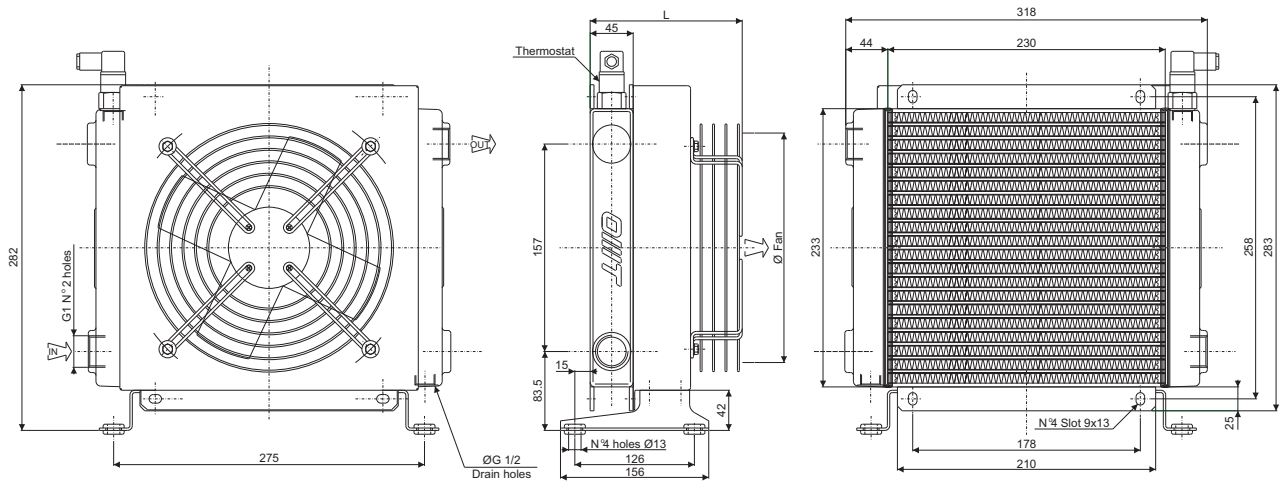

Coefficiente di correzione Correction factor

CST	10	15	20	32	40	50	60	80	100	200
F	0.51	0.66	0.76	1	1.22	1.4	1.6	1.9	2.1	3.4

Diagramma di rendimento Performance diagram



Diagramma perdite di carico (32 cst) Pressure drop diagram (32 cst)



Scambiatore tipo SS20 Serie Aria-Olio Heat exchanger series SS20 Air-Oil version

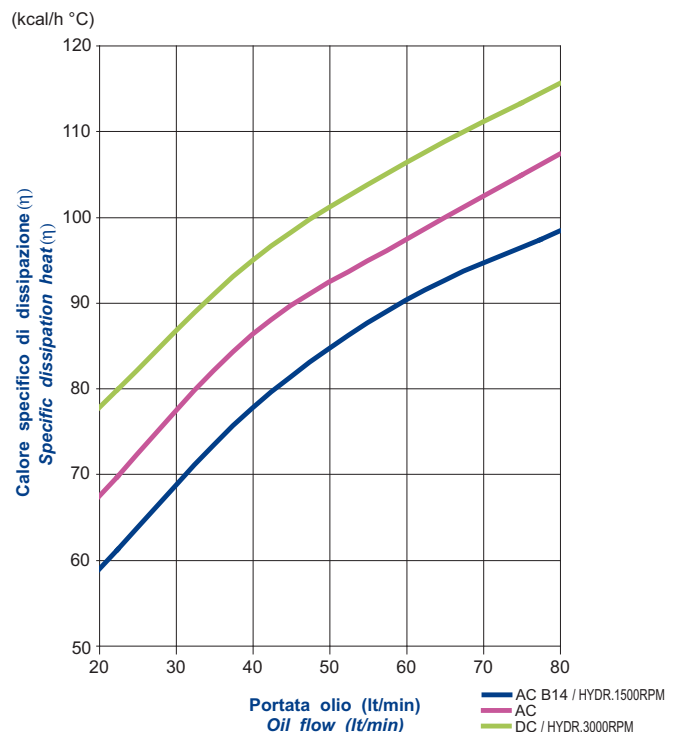
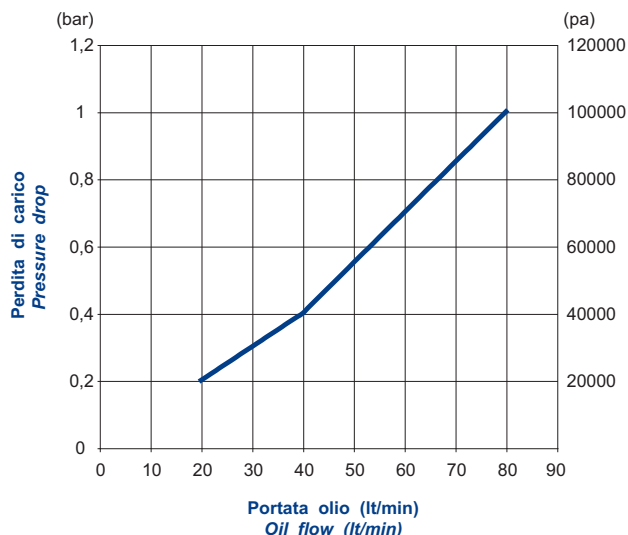

CARATTERISTICHE TECNICHE DEL GRUPPO DI VENTILAZIONE TECHNICAL FEATURES

Tipologia Type	Frequenza Frequency Hz	Tensione Voltage V	N° Giri/min RPM	Potenza Power kW	Diam. Ventola Ø FAN (mm)	dB (A)	L (mm)	Q air (m³/h)	Cap. (lt)	Peso Weight (kg)	IP
01	50/60	230	2600/2900	0.064/0.078	200	67	170	890	0.68	8	4
03	50/60	400	2600/2900	0.068/0.070	200	67	170	890	0.68	8	44
14	50/60	230/400	1370/1650	0.25	200	67	364	700	0.68	11	55
12	DC	12	3100	0.100	225	66	176	1200	0.68	7	65
24	DC	24	3000	0.100	225	66	176	1200	0.68	7	65
G2	-	-	-	-	200	-	-	-	-	7	-

Portata olio consigliata da 30 a 100 (lt/min)
Suggested oil flow from 30 to 100 (lt/min)

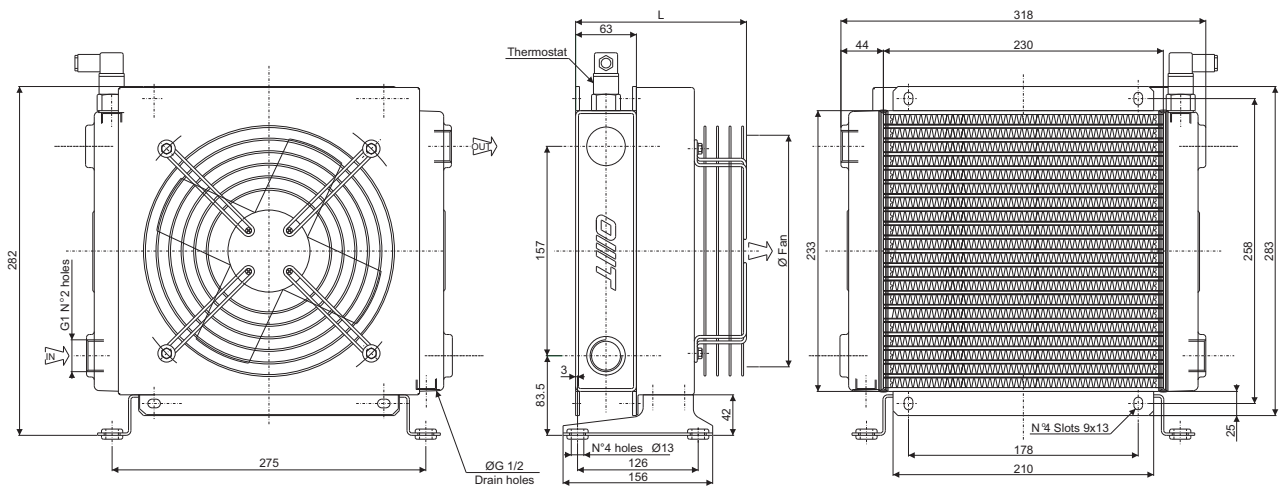

Coefficiente di correzione Correction factor

CST	10	15	20	32	40	50	60	80	100	200
F	0.51	0.66	0.76	1	1.22	1.4	1.6	1.9	2.1	3.4

Diagramma di rendimento Performance diagram



Diagramma perdite di carico (32 cst) Pressure drop diagram (32 cst)



Scambiatore tipo SS24 Serie Aria-Olio Heat exchanger series SS24 Air-Oil version

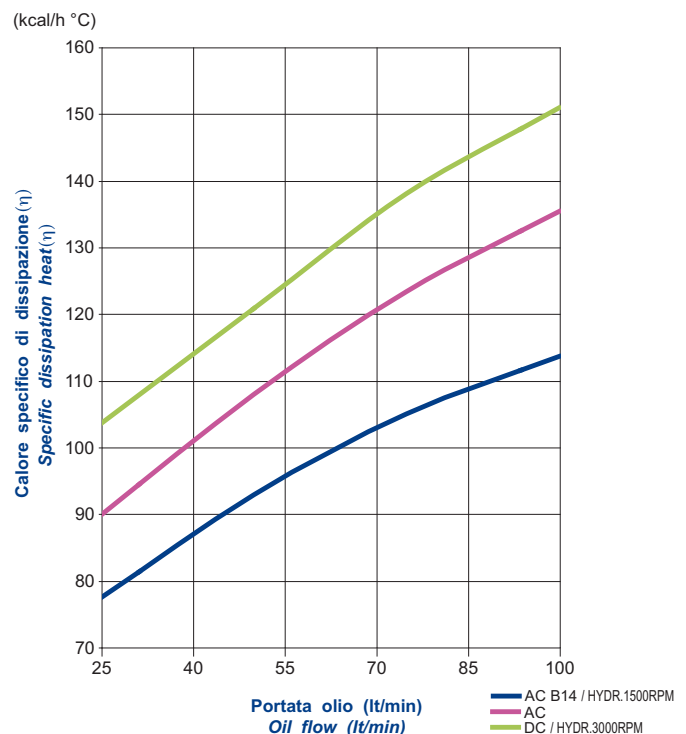
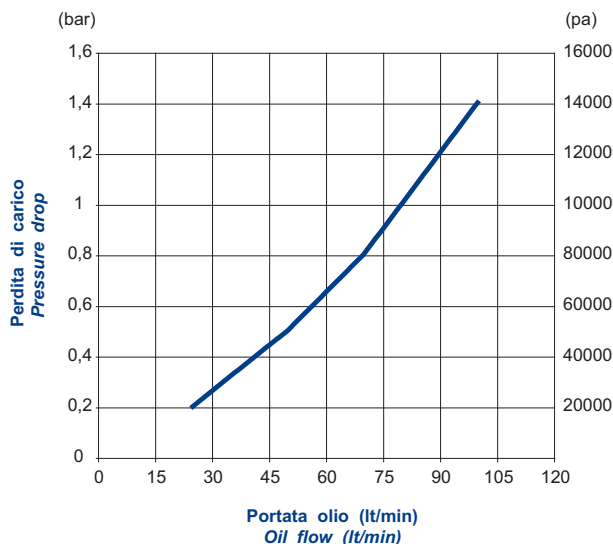

CARATTERISTICHE TECNICHE DEL GRUPPO DI VENTILAZIONE TECHNICAL FEATURES

Tipologia Type	Frequenza Frequency Hz	Tensione Voltage V	N° Giri/min RPM	Potenza Power kW	Diam. Ventola Ø FAN (mm)	dB (A)	L (mm)	Q air (m³/h)	Cap. (lt)	Peso Weight (kg)	IP
01	50/60	230	2550/2750	0.11/0.16	250	68	169	1780	0.9	11	44
03	50/60	400	2500/2650	0.10/0.14	250	68	169	1780	0.9	11	44
14	50/60	230/400	1370	0.25	250	68	364	1500	0.9	15.5	55
12	DC	12	3000	0.100	280	66	176	1600	0.9	10	65
24	DC	24	3000	0.100	280	66	176	1600	0.9	10	65
G2	-	-	-	-	250	-	-	-	-	10	-

Portata olio consigliata da 40 a 120 (lt/min)
Suggested oil flow from 40 to 120 (lt/min)

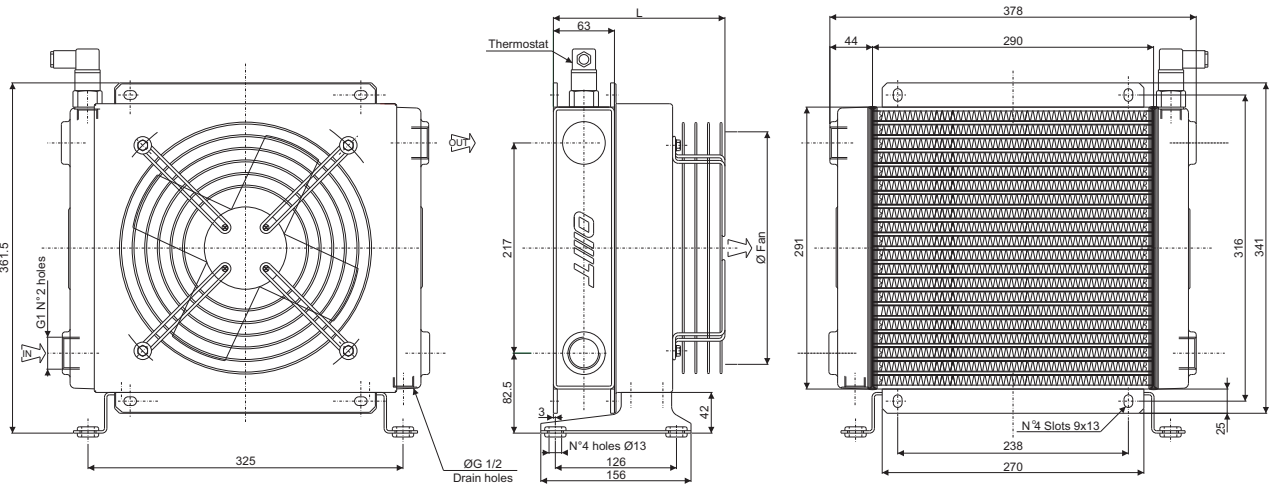

Coefficiente di correzione Correction factor

CST	10	15	20	32	40	50	60	80	100	200
F	0.51	0.66	0.76	1	1.22	1.4	1.6	1.9	2.1	3.4

Diagramma di rendimento Performance diagram



Diagramma perdite di carico (32 cst) Pressure drop diagram (32 cst)



Scambiatore tipo SS30 Serie Aria-Olio Heat exchanger series SS30 Air-Oil version

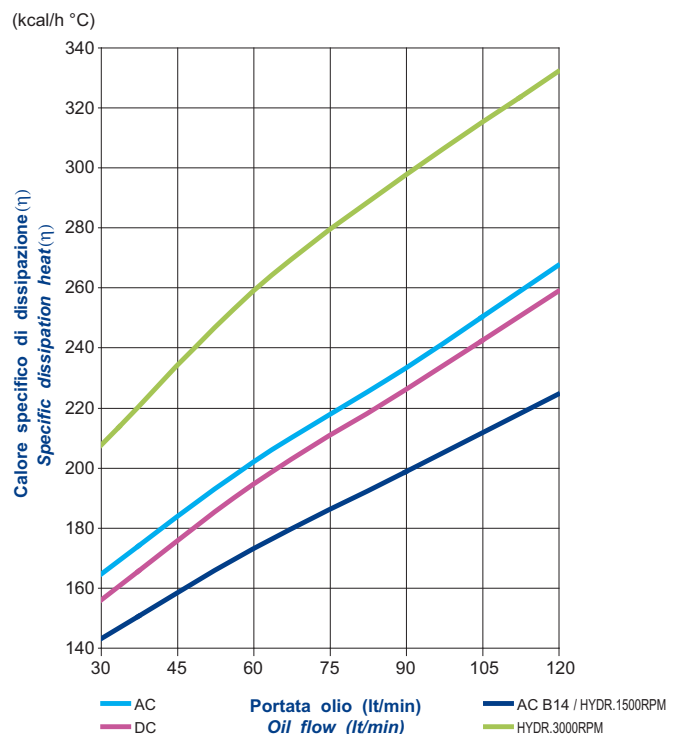
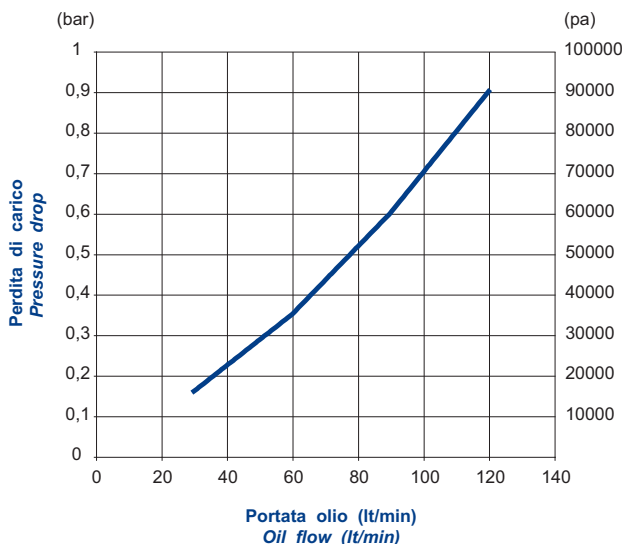

CARATTERISTICHE TECNICHE DEL GRUPPO DI VENTILAZIONE TECHNICAL FEATURES

Tipologia Type	Frequenza Frequency Hz	Tensione Voltage V	N° Giri/min RPM	Potenza Power kW	Diam. Ventola Ø FAN (mm)	dB (A)	L (mm)	Q air (m³/h)	Cap. (lt)	Peso Weight (kg)	IP
01	50/60	230	2700/3000	0.23/0.35	300	69	183	3290	1.5	15	44
03	50/60	400	2600/2850	0.19/0.27	300	69	183	3290	1.5	15	44
14	50/60	230/400	1390	0.37	300	69	404	2000	1.5	20	55
12	DC	12	3000	0.175	305	67	219	2300	1.5	14	65
24	DC	24	3000	0.175	305	67	219	2300	1.5	14	65
G2	-	-	-	-	300	-	238	-	1.5	14.5	-

Portata olio consigliata da 35 a 140 (lt/min)
Suggested oil flow from 35 to 140 (lt/min)

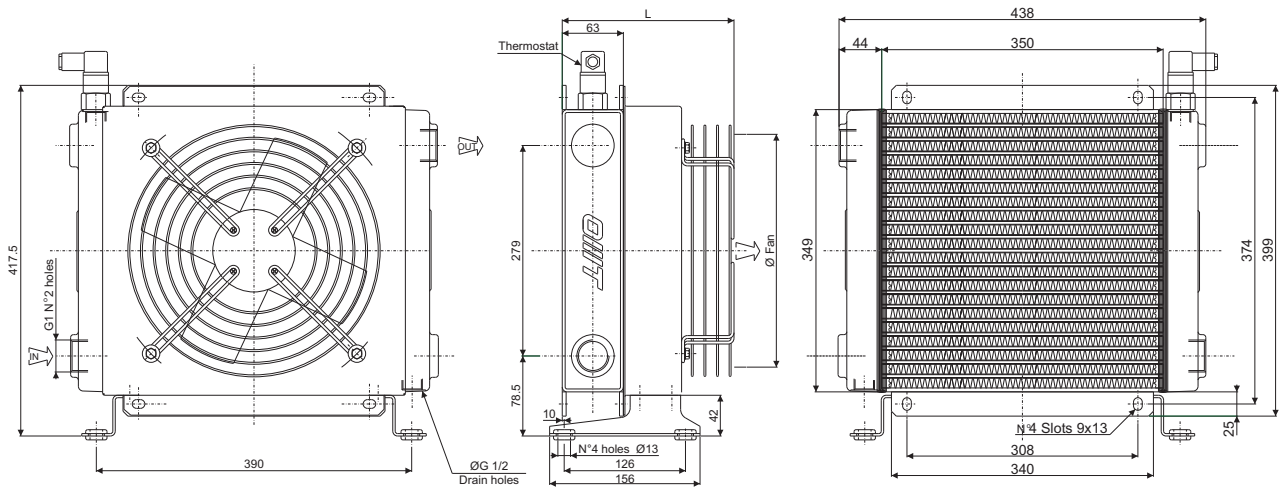

Coefficiente di correzione Correction factor

CST	10	15	20	32	40	50	60	80	100	200
F	0.51	0.66	0.76	1	1.22	1.4	1.6	1.9	2.1	3.4

Diagramma di rendimento Performance diagram



Diagramma perdite di carico (32 cst) Pressure drop diagram (32 cst)



Scambiatore tipo SS40 Serie Aria-Olio Heat exchanger series SS40 Air-Oil version

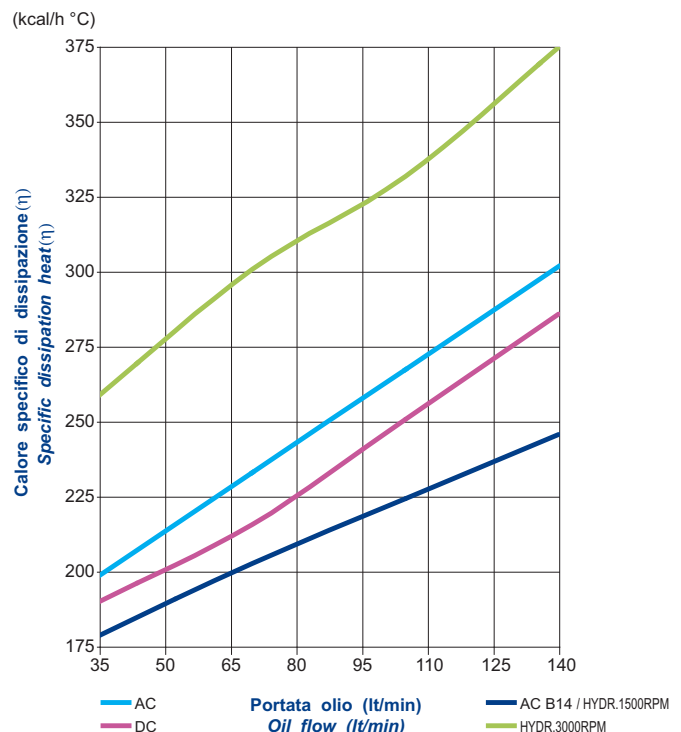
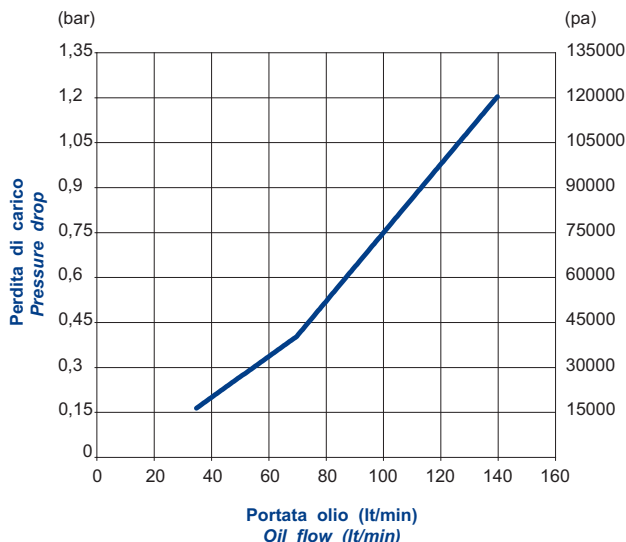

CARATTERISTICHE TECNICHE DEL GRUPPO DI VENTILAZIONE TECHNICAL FEATURES

Tipologia Type	Frequenza Frequency Hz	Tensione Voltage V	N° Giri/min RPM	Potenza Power kW	Diam. Ventola Ø FAN (mm)	dB (A)	L (mm)	Q air (m³/h)	Cap. (lt)	Peso Weight (kg)	IP
01	50/60	230	1440/1700	0.16/0.24	400	71	223	4000	2.6	21	44
03	50/60	400	1450/1690	0.13/0.18	400	71	223	4000	2.6	21	44
14	50/60	230/400	1430	0.55	400	71	446	4000	2.6	25	55
12	DC	12	2500	0.200	385	69	229	3500	2.6	20	65
24	DC	24	2500	0.200	385	71	229	3500	2.6	20	65
G2	-	-	-	-	400	-	248	-	2.6	19	-

Portata olio consigliata da 40 a 160 (lt/min)
Suggested oil flow from 40 to 160 (lt/min)

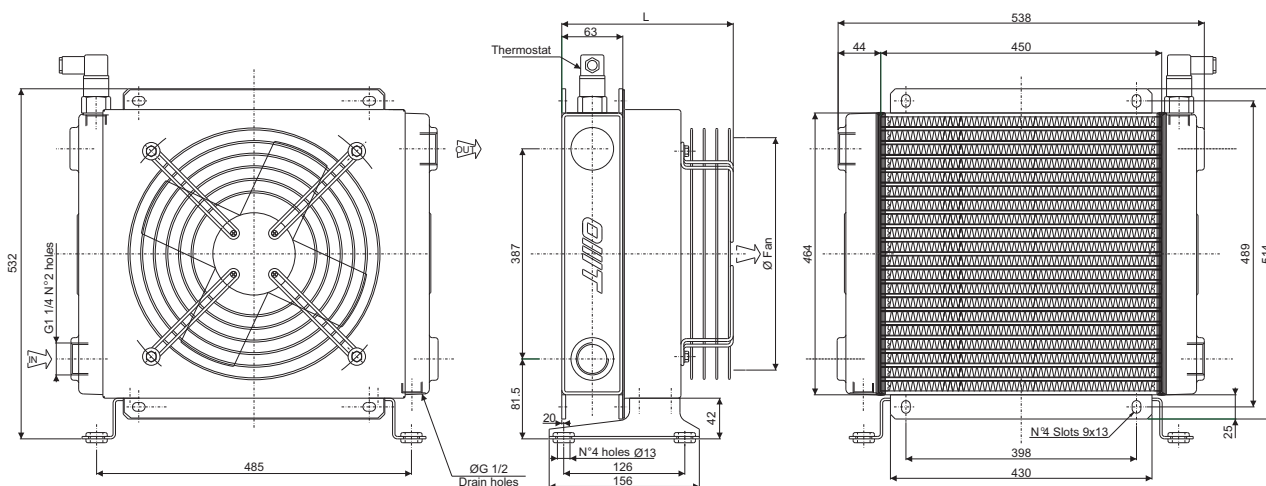

Coefficiente di correzione Correction factor

CST	10	15	20	32	40	50	60	80	100	200
F	0.51	0.66	0.76	1	1.22	1.4	1.6	1.9	2.1	3.4

Diagramma di rendimento Performance diagram



Diagramma perdite di carico (32 cst) Pressure drop diagram (32 cst)



Scambiatore tipo SS50 Serie Aria-Olio Heat exchanger series SS50 Air-Oil version

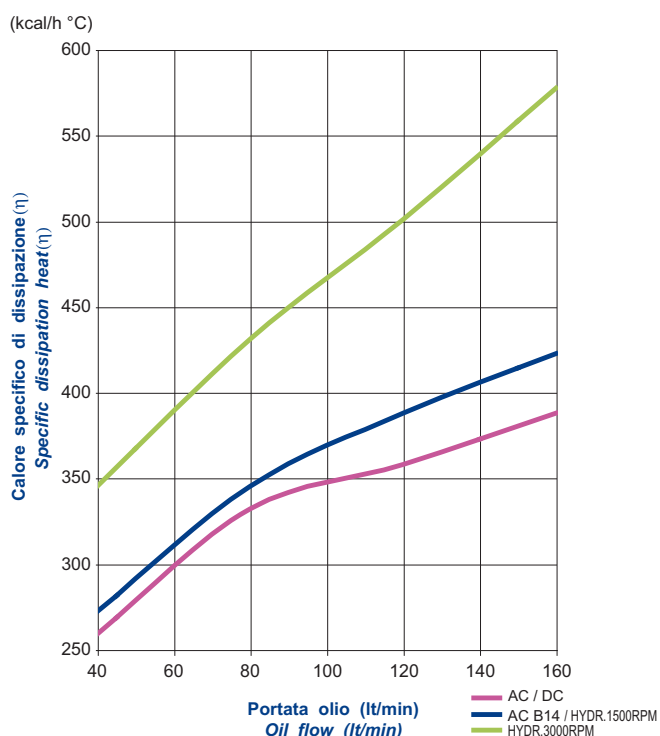
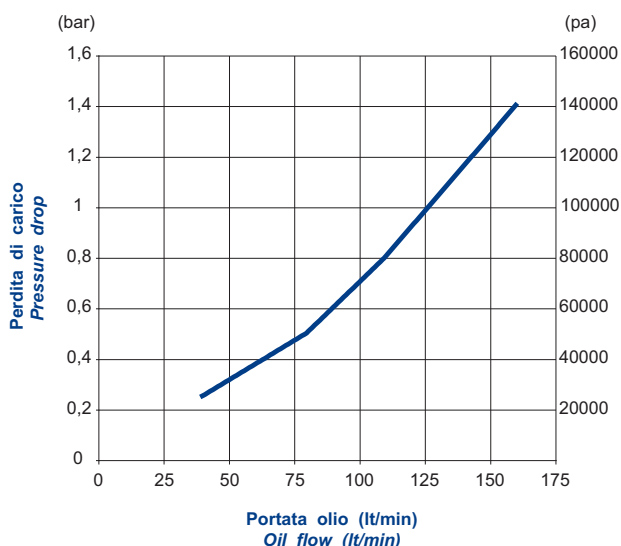

CARATTERISTICHE TECNICHE DEL GRUPPO DI VENTILAZIONE TECHNICAL FEATURES

Tipologia Type	Frequenza Frequency Hz	Tensione Voltage V	N° Giri/min RPM	Potenza Power kW	Diam. Ventola Ø FAN (mm)	dB (A)	L (mm)	Q air (m³/h)	Cap. (lt)	Peso Weight (kg)	IP
03	50/60	230/400	1380/1840	0.20/0.28	450	73	290	6830	4.9	27	44
14	50/60	230/400	1430	0.75	450	73	446	6830	4.9	30	55
12	DC	12	3000	0.145 (x2)	280	73	207	4200	4.9	24	65
24	DC	24	3000	0.145 (x2)	280	73	207	4200	4.9	24	65
G2	-	-	-	-	450	-	248	-	4.9	23	-

Portata olio consigliata da 50 a 180 (lt/min)
Suggested oil flow from 50 to 180 (lt/min)

(x2) = doppio motore
(x2) = double engine

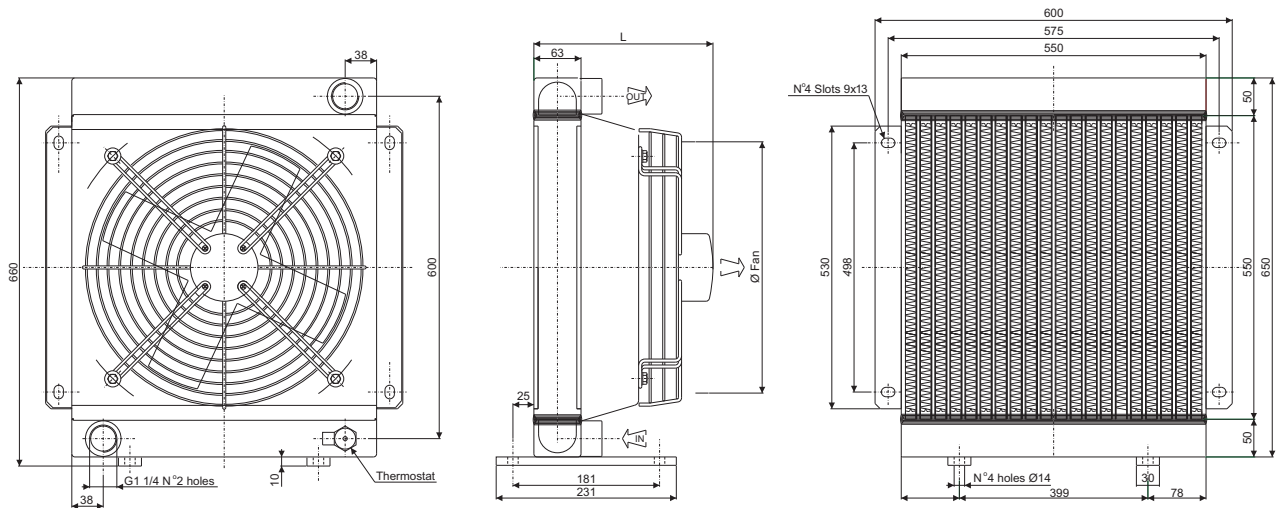

Coefficiente di correzione Correction factor

CST	10	15	20	32	40	50	60	80	100	200
F	0.51	0.66	0.76	1	1.22	1.4	1.6	1.9	2.1	3.4

Diagramma perdite di carico (32 cst) Pressure drop diagram (32 cst)



Diagramma di rendimento Performance diagram



Scambiatore tipo SS215 2pass Serie Aria-Olio Heat exchanger series SS215 2pass Air-Oil version

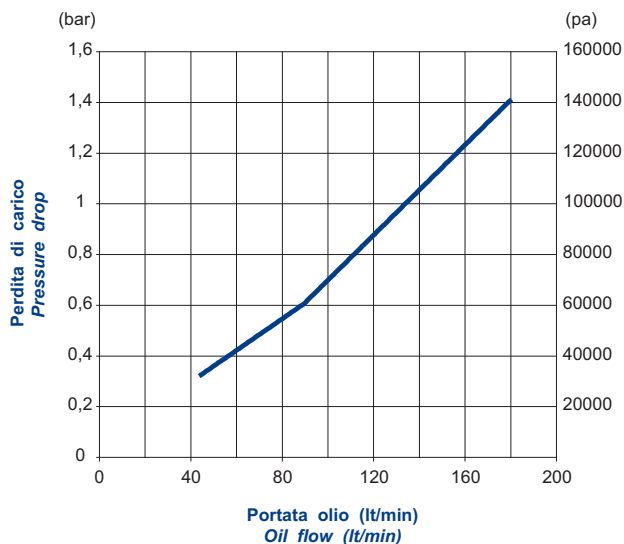
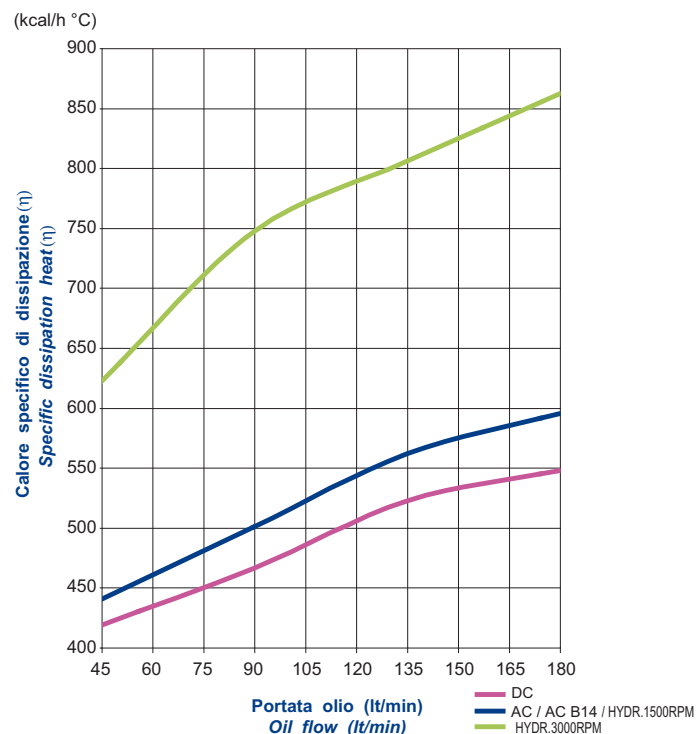

CARATTERISTICHE TECNICHE DEL GRUPPO DI VENTILAZIONE TECHNICAL FEATURES

Tipologia Type	Frequenza Frequency Hz	Tensione Voltage V	N° Giri/min RPM	Potenza Power kW	Diam. Ventola Ø FAN (mm)	dB (A)	L (mm)	Q air (m³/h)	Cap. (lt)	Peso Weight (kg)	IP
01	50/60	230	2600/2900	0.064/0.078	200	67	152	890	0.48	7	44
03	50/60	400	2600/2900	0.068/0.070	200	67	152	890	0.48	7	44
14	50/60	230/400	1370/1650	0.25	200	67	346	700	0.48	10	55
12	DC	12	3100	0.100	225	66	158	1200	0.48	6.5	65
24	DC	24	3000	0.100	225	66	158	1200	0.48	6.5	65
G2	-	-	-	-	200	-	-	-	-	6	-

Portata olio consigliata da 5 a 40 (lt/min)
Suggested oil flow from 5 to 40 (lt/min)

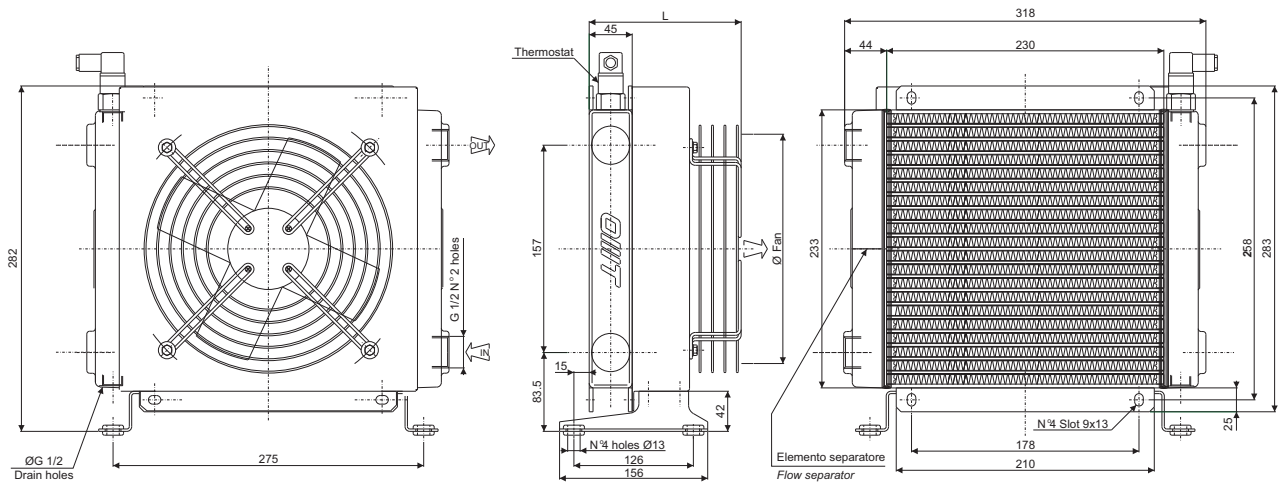

Coefficiente di correzione Correction factor

CST	10	15	20	32	40	50	60	80	100	200
F	0.51	0.66	0.76	1	1.22	1.4	1.6	1.9	2.1	3.4

Diagramma di rendimento Performance diagram



Diagramma perdite di carico (32 cst) Pressure drop diagram (32 cst)



Scambiatore tipo SS220 2pass Serie Aria-Olio Heat exchanger series SS220 2pass Air-Oil version

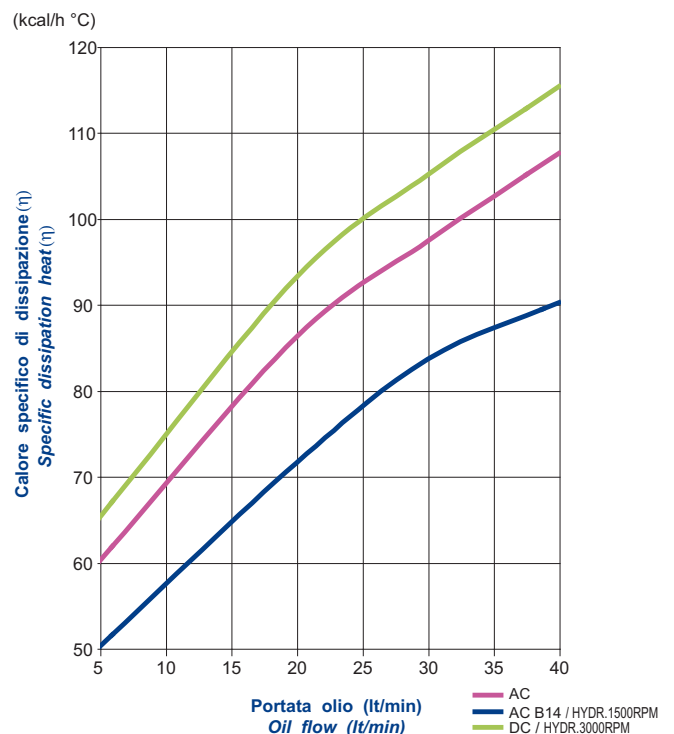
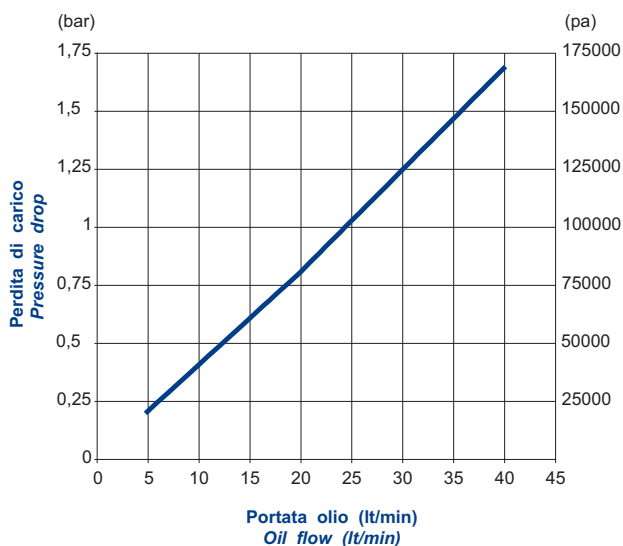

CARATTERISTICHE TECNICHE DEL GRUPPO DI VENTILAZIONE TECHNICAL FEATURES

Tipologia Type	Frequenza Frequency Hz	Tensione Voltage V	N° Giri/min RPM	Potenza Power kW	Diam. Ventola Ø FAN (mm)	dB (A)	L (mm)	Q air (m³/h)	Cap. (lt)	Peso Weight (kg)	IP
01	50/60	230	2600/2900	0.064/0.078	200	67	170	890	0.68	8	44
03	50/60	400	2600/2900	0.068/0.070	200	67	170	890	0.68	8	44
14	50/60	230/400	1370/1650	0.25	200	67	364	700	0.68	11	55
12	DC	12	3100	0.100	225	66	176	1200	0.68	7	65
24	DC	24	3000	0.100	225	66	176	1200	0.68	7	65
G2	-	-	-	-	200	-	-	-	-	7	-

Portata olio consigliata da 5 a 40 (lt/min)
Suggested oil flow from 5 to 40 (lt/min)

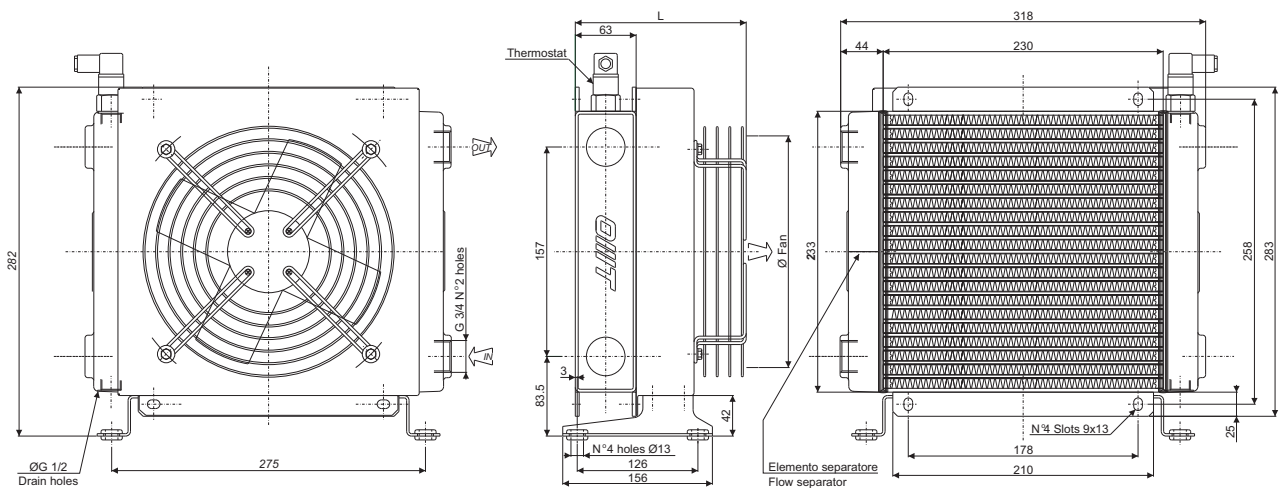

Coefficiente di correzione Correction factor

CST	10	15	20	32	40	50	60	80	100	200
F	0.51	0.66	0.76	1	1.22	1.4	1.6	1.9	2.1	3.4

Diagramma di rendimento Performance diagram



Diagramma perdite di carico (32 cst) Pressure drop diagram (32 cst)



Scambiatore tipo SS224 2pass Serie Aria-Olio Heat exchanger series SS224 2pass Air-Oil version

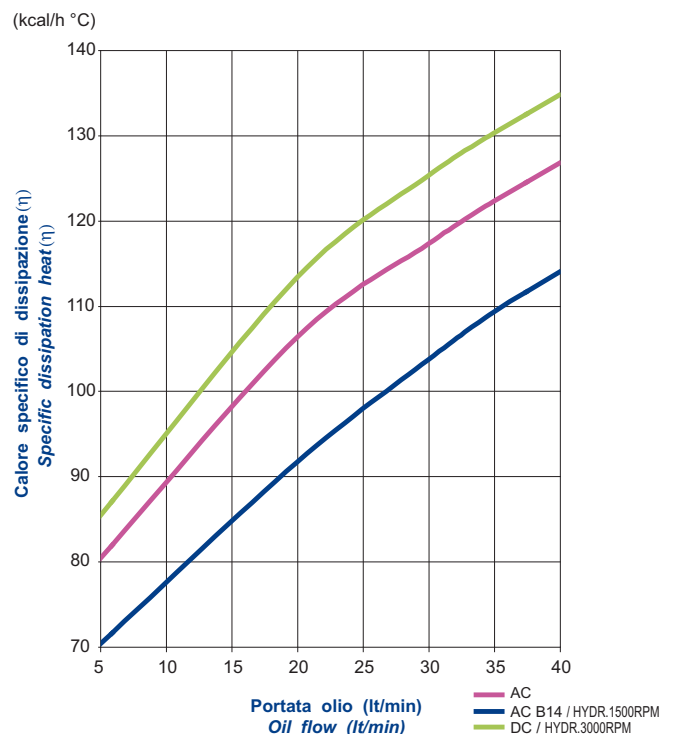
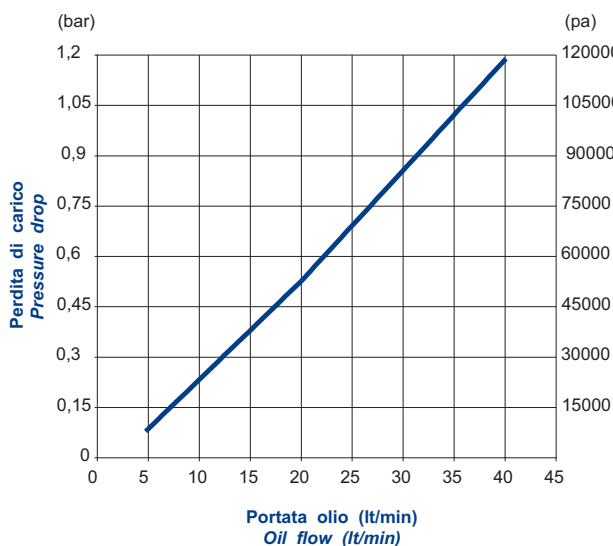

CARATTERISTICHE TECNICHE DEL GRUPPO DI VENTILAZIONE TECHNICAL FEATURES

Tipologia Type	Frequenza Frequency Hz	Tensione Voltage V	N° Giri/min RPM	Potenza Power kW	Diam. Ventola Ø FAN (mm)	dB (A)	L (mm)	Q air (m³/h)	Cap. (lt)	Peso Weight (kg)	IP
01	50/60	230	2550/2750	0.11/0.16	250	67	169	1780	0.9	11	44
03	50/60	400	2500/2650	0.10/0.14	250	67	169	1780	0.9	11	44
14	50/60	230/400	1370	0.25	250	67	364	1500	0.9	15.5	55
12	DC	12	3000	0.100	280	66	176	1600	0.9	10	65
24	DC	24	3000	0.100	280	66	176	1600	0.9	10	65
G2	-	-	-	-	250	-	-	-	-	10	-

Portata olio consigliata da 10 a 60 (lt/min)
Suggested oil flow from 10 to 60 (lt/min)

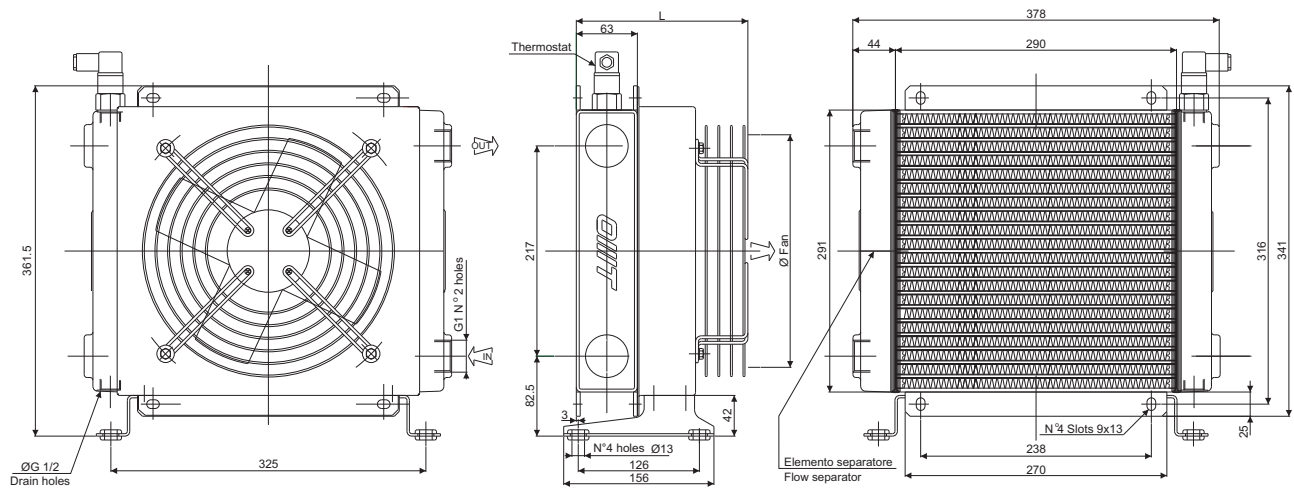

Coefficiente di correzione Correction factor

CST	10	15	20	32	40	50	60	80	100	200
F	0.51	0.66	0.76	1	1.22	1.4	1.6	1.9	2.1	3.4

Diagramma di rendimento Performance diagram



Diagramma perdite di carico (32 cst) Pressure drop diagram (32 cst)



Scambiatore tipo SS230 2pass Serie Aria-Olio Heat exchanger series SS230 2pass Air-Oil version

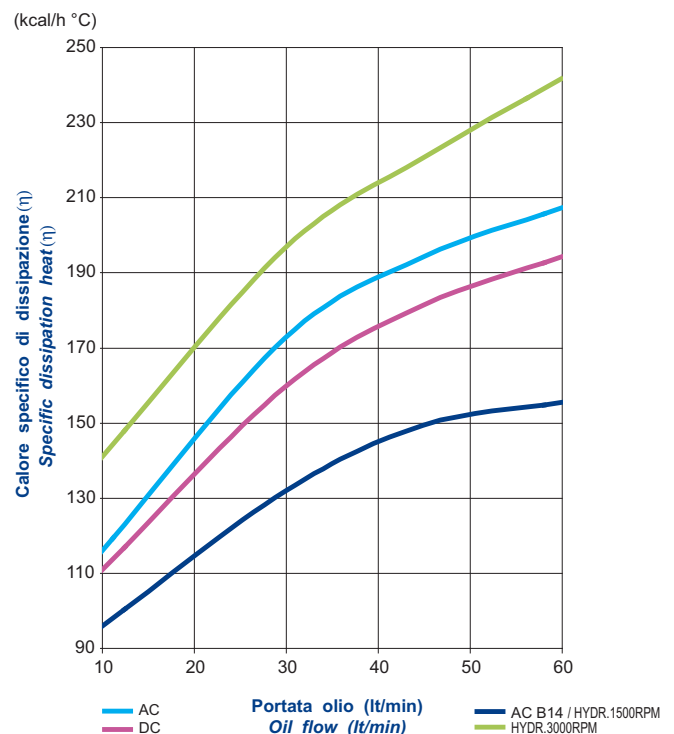
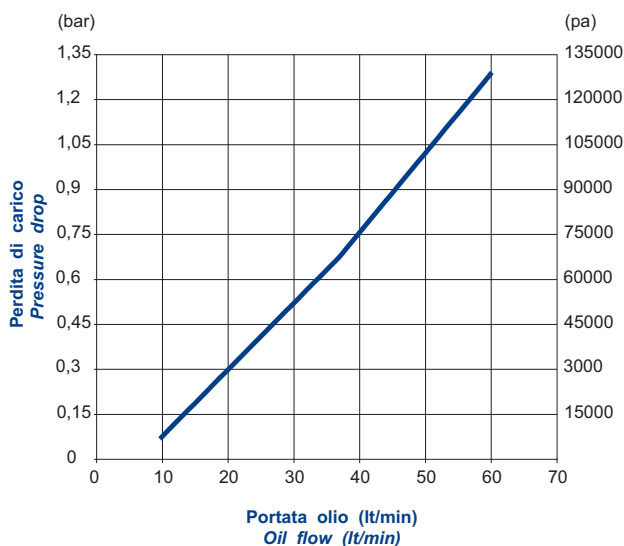

CARATTERISTICHE TECNICHE DEL GRUPPO DI VENTILAZIONE TECHNICAL FEATURES

Tipologia Type	Frequenza Frequency Hz	Tensione Voltage V	N° Giri/min RPM	Potenza Power kW	Diam. Ventola Ø FAN (mm)	dB (A)	L (mm)	Q air (m³/h)	Cap. (lt)	Peso Weight (kg)	IP
01	50/60	230	2700/3000	0.23/0.35	300	69	183	3290	1.5	15	44
03	50/60	400	2600/2850	0.19/0.27	300	69	183	3290	1.5	15	44
14	50/60	230/400	1390	0.37	300	69	404	2000	1.5	20	55
12	DC	12	3000	0.175	305	67	219	2300	1.5	14	65
24	DC	24	3000	0.175	305	67	219	2300	1.5	14	65
G2	-	-	-	-	300	-	238	-	1.5	14.5	-

Portata olio consigliata da 15 a 60 (lt/min)
Suggested oil flow from 15 to 60 (lt/min)

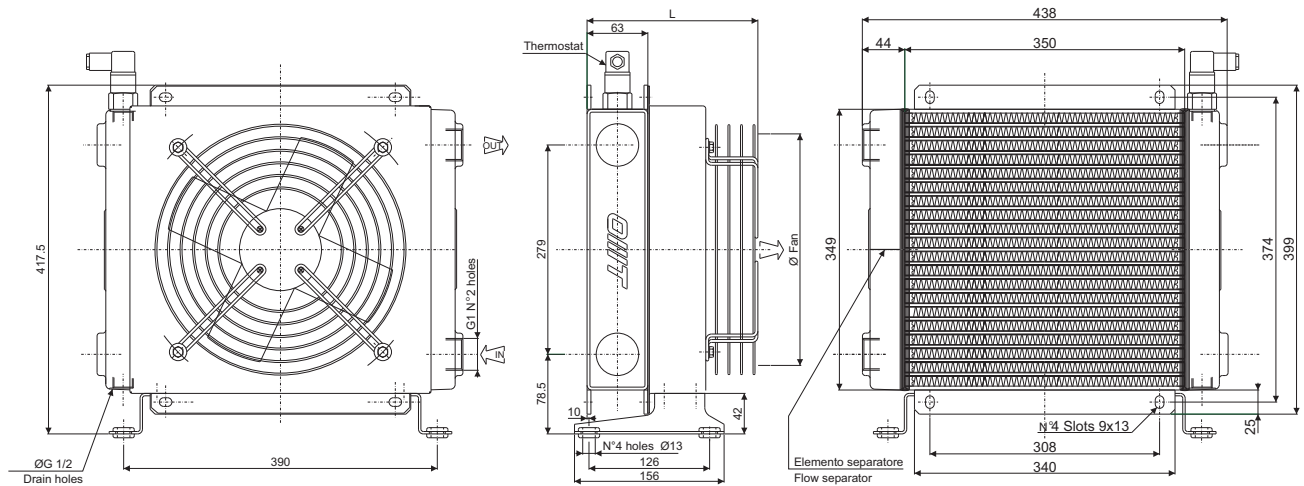

Coefficiente di correzione Correction factor

CST	10	15	20	32	40	50	60	80	100	200
F	0.51	0.66	0.76	1	1.22	1.4	1.6	1.9	2.1	3.4

Diagramma di rendimento Performance diagram



Diagramma perdite di carico (32 cst) Pressure drop diagram (32 cst)



Scambiatore tipo SS240 2pass Serie Aria-Olio Heat exchanger series SS240 2pass Air-Oil version

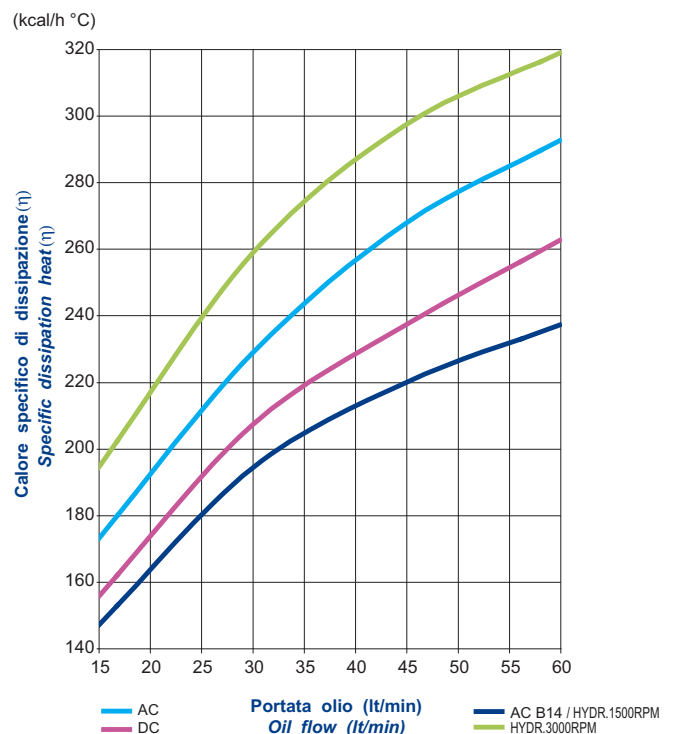
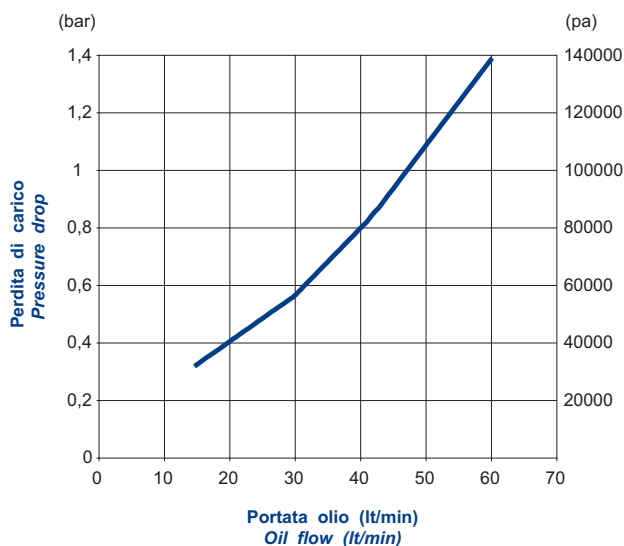

CARATTERISTICHE TECNICHE DEL GRUPPO DI VENTILAZIONE TECHNICAL FEATURES

Tipologia Type	Frequenza Frequency Hz	Tensione Voltage V	N° Giri/min RPM	Potenza Power kW	Diam. Ventola Ø FAN (mm)	dB (A)	L (mm)	Q air (m³/h)	Cap. (lt)	Peso Weight (kg)	IP
01	50/60	230	1440/1700	0.16/0.24	400	71	223	4000	2.6	21	44
03	50/60	400	1450/1690	0.13/0.18	400	71	223	4000	2.6	21	44
14	50/60	230/400	1430	0.55	400	71	446	4000	2.6	25	55
12	DC	12	2500	0.200	385	69	229	3500	2.6	20	65
24	DC	24	2500	0.200	385	71	229	3500	2.6	20	65
G2	-	-	-	-	400	-	248	-	2.6	19	-

Portata olio consigliata da 20 a 80 (lt/min)
Suggested oil flow from 20 to 80 (lt/min)

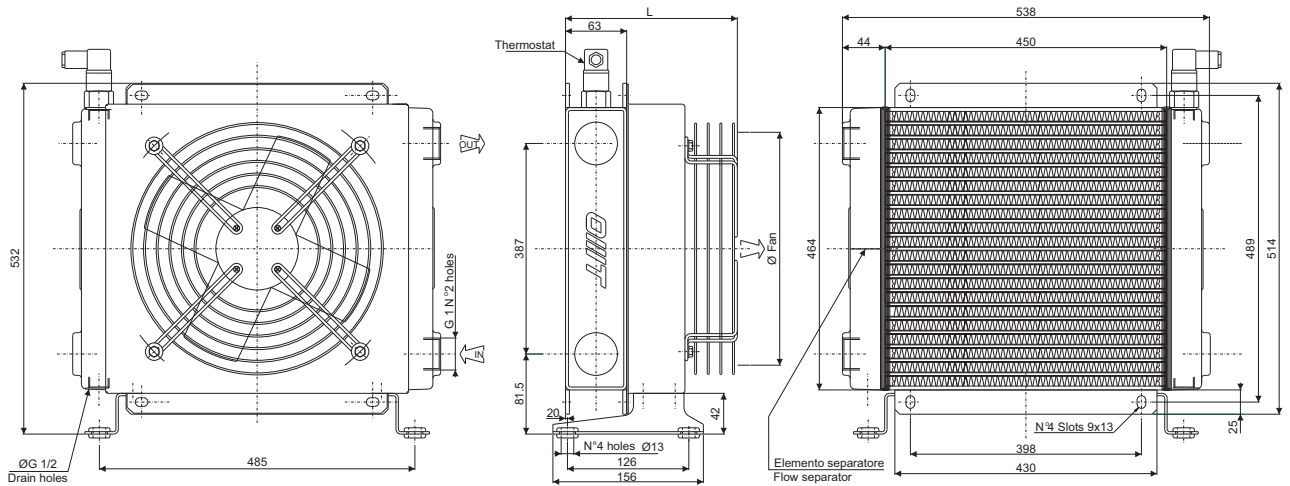

Coefficiente di correzione Correction factor

CST	10	15	20	32	40	50	60	80	100	200
F	0.51	0.66	0.76	1	1.22	1.4	1.6	1.9	2.1	3.4

Diagramma perdite di carico (32 cst) Pressure drop diagram (32 cst)



Diagramma di rendimento Performance diagram



Scambiatore tipo SD20 Serie Aria-Olio Heat exchanger series SD20 Air-Oil version

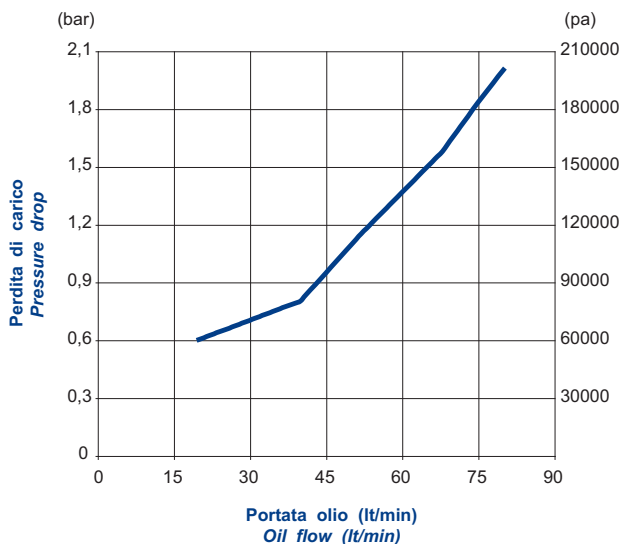
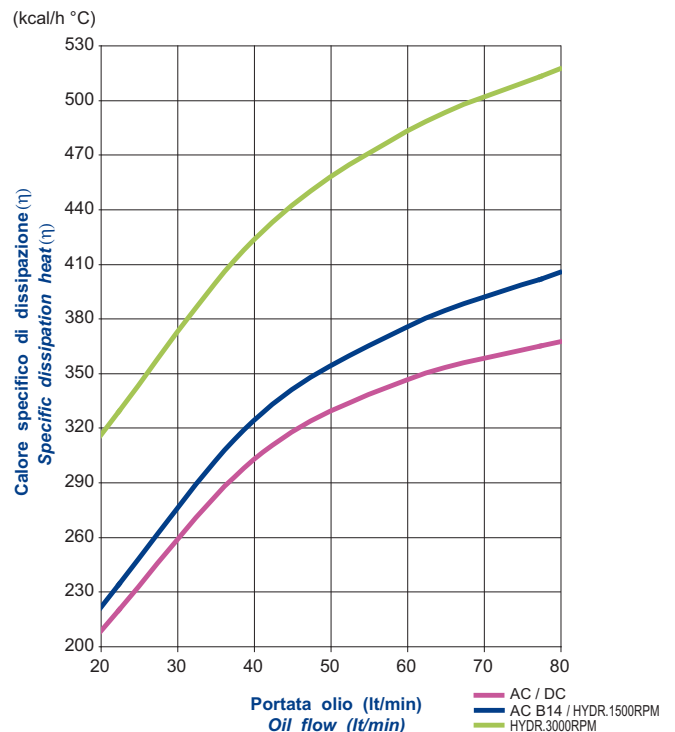

CARATTERISTICHE TECNICHE DEL GRUPPO DI VENTILAZIONE TECHNICAL FEATURES

Tipologia Type	Frequenza Frequency Hz	Tensione Voltage V	N° Giri/min RPM	Potenza Power kW	Diam. Ventola Ø FAN (mm)	dB (A)	L (mm)	Q air (m³/h)	Cap. (lt)	Peso Weight (kg)	IP
01	50/60	230	2600/2900	0.064/0.078 (x2)	200	67	170	1780	1.3	17	44
03	50/60	400	2600/2900	0.068/0.070 (x2)	200	67	170	1780	1.3	17	44
14	50/60	230/400	1370/1650	0.25 (x2)	200	67	364	1400	1.3	23	55
12	DC	12	3100	0.100 (x2)	225	66	176	2400	1.3	15	65
24	DC	24	3000	0.100 (x2)	225	66	176	2400	1.3	15	65
G2	-	-	-	-	200	-	-	-	-	17	-

Portata olio consigliata da 60 a 180 (lt/min)
Suggested oil flow from 60 to 180 (lt/min)

(x2) = doppio motore
(x2) = double engine

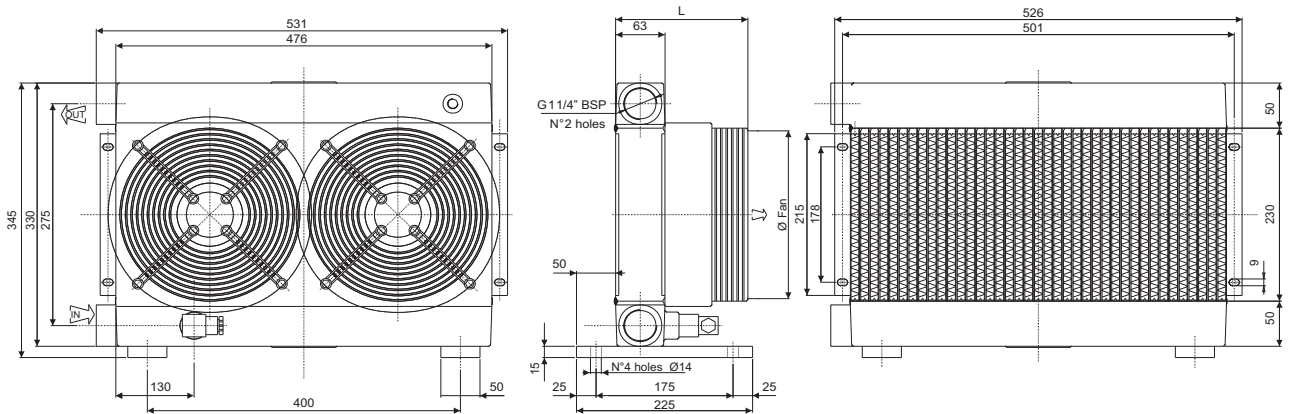

Coefficiente di correzione Correction factor

CST	10	15	20	32	40	50	60	80	100	200
F	0.51	0.66	0.76	1	1.22	1.4	1.6	1.9	2.1	3.4

Diagramma di rendimento Performance diagram



Diagramma perdite di carico (32 cst) Pressure drop diagram (32 cst)



Scambiatore tipo SD24 Serie Aria-Olio Heat exchanger series SD24 Air-Oil version

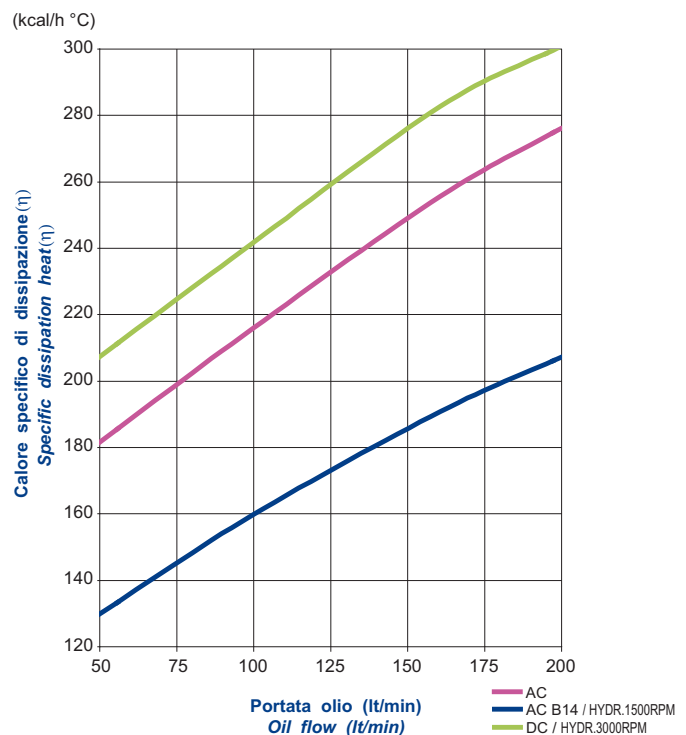
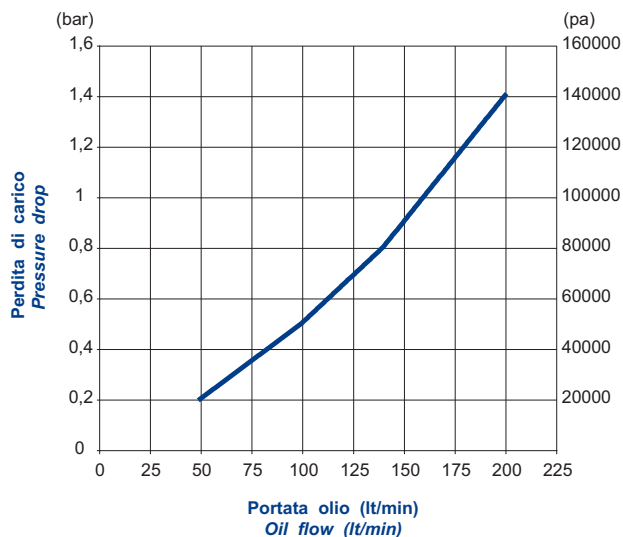

CARATTERISTICHE TECNICHE DEL GRUPPO DI VENTILAZIONE TECHNICAL FEATURES

Tipologia Type	Frequenza Frequency Hz	Tensione Voltage V	N° Giri/min RPM	Potenza Power kW	Diam. Ventola Ø FAN (mm)	dB (A)	L (mm)	Q air (m³/h)	Cap. (lt)	Peso Weight (kg)	IP
01	50/60	230	2550/2750	0.11/0.16 (x2)	250	68	169	3560	1.9	23	44
03	50/60	400	2500/2650	0.10/0.14 (x2)	250	68	169	3560	1.9	23	44
14	50/60	230/400	1370	0.25 (x2)	250	68	364	3000	1.9	34	55
12	DC	12	3000	0.100 (x2)	280	66	176	3200	1.9	21	65
24	DC	24	3000	0.100 (x2)	280	66	176	3200	1.9	21	65
G2	-	-	-	-	250	-	-	-	-	23	-

Portata olio consigliata da 80 a 220 (lt/min)
Suggested oil flow from 80 to 220 (lt/min)

(x2) = doppio motore
(x2) = double engine

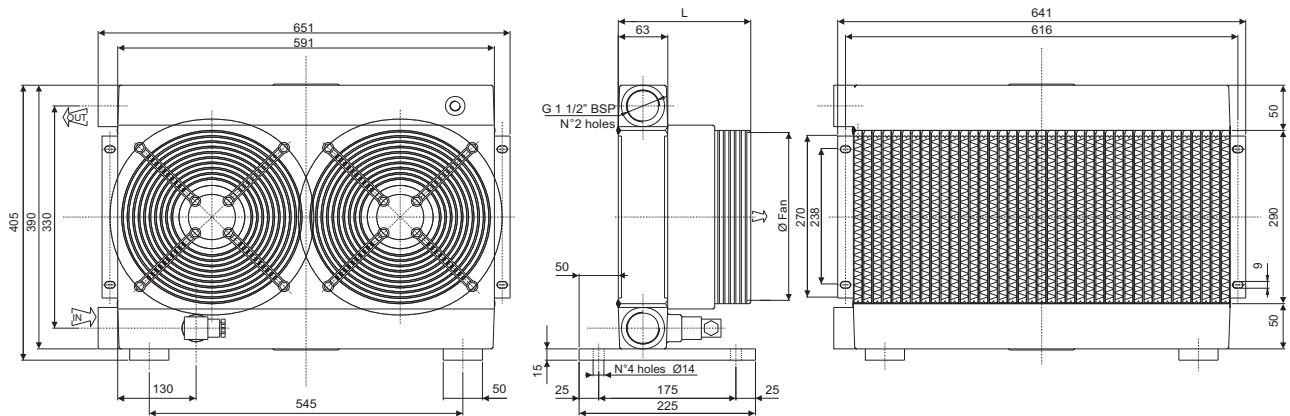

Coefficiente di correzione Correction factor

CST	10	15	20	32	40	50	60	80	100	200
F	0.51	0.66	0.76	1	1.22	1.4	1.6	1.9	2.1	3.4

Diagramma di rendimento Performance diagram



Diagramma perdite di carico (32 cst) Pressure drop diagram (32 cst)



Scambiatore tipo SD30 Serie Aria-Olio Heat exchanger series SD30 Air-Oil version

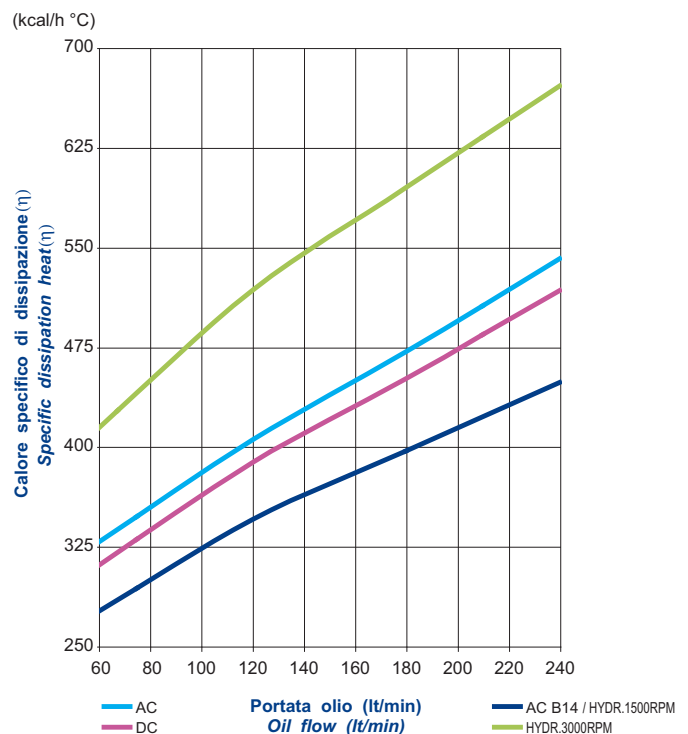
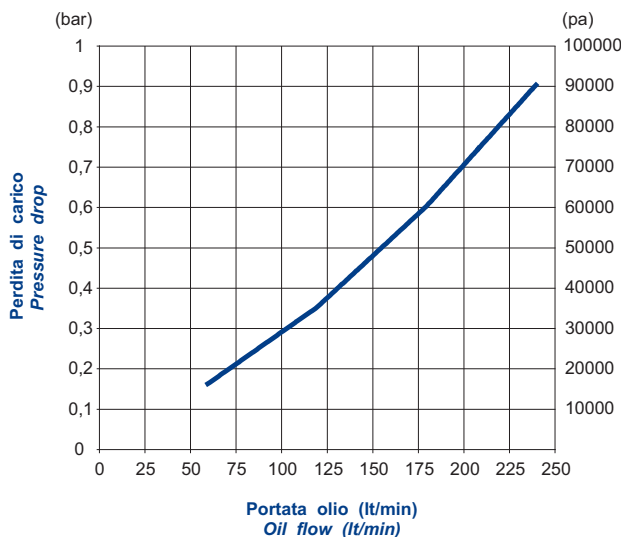

CARATTERISTICHE TECNICHE DEL GRUPPO DI VENTILAZIONE TECHNICAL FEATURES

Tipologia Type	Frequenza Frequency Hz	Tensione Voltage V	N° Giri/min RPM	Potenza Power kW	Diam. Ventola Ø FAN (mm)	dB (A)	L (mm)	Q air (m³/h)	Cap. (lt)	Peso Weight (kg)	IP
01	50/60	230	2700/3000	0.23/0.35 (x2)	300	69	183	6580	3.1	31	44
03	50/60	400	2600/2850	0.19/0.27 (x2)	300	69	183	6580	3.1	31	44
14	50/60	230/400	1390	0.37 (x2)	300	69	404	4000	3.1	42	55
12	DC	12	3000	0.175 (x2)	305	67	219	4600	3.1	29	65
24	DC	24	3000	0.175 (x2)	305	67	219	4600	3.1	29	65
G2	-	-	-	-	300	-	238	-	3.1	30	-

Portata olio consigliata da 80 a 260 (lt/min)
Suggested oil flow from 80 to 260 (lt/min)

(x2) = doppio motore
(x2) = double engine

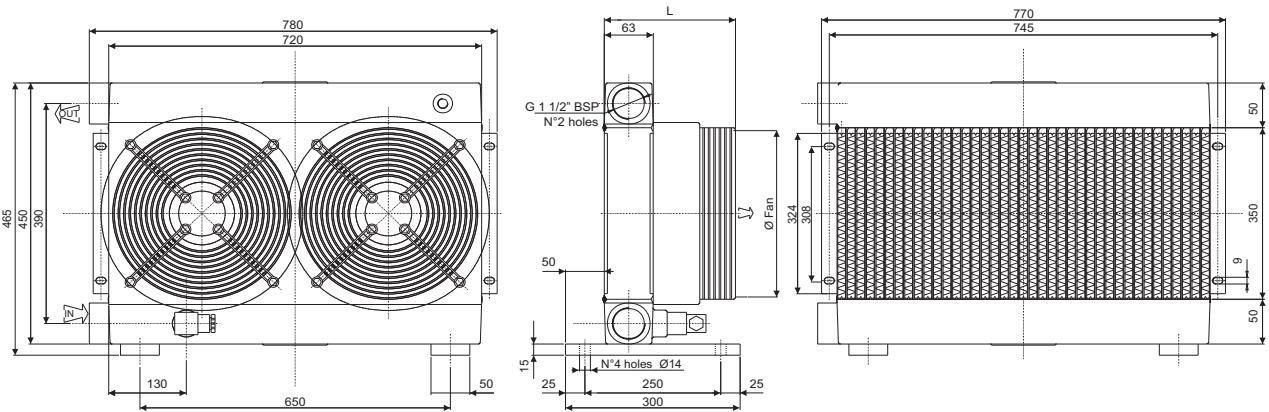

Coefficiente di correzione Correction factor

CST	10	15	20	32	40	50	60	80	100	200
F	0.51	0.66	0.76	1	1.22	1.4	1.6	1.9	2.1	3.4

Diagramma di rendimento Performance diagram



Diagramma perdite di carico (32 cst) Pressure drop diagram (32 cst)



Scambiatore tipo SD40 Serie Aria-Olio Heat exchanger series SD40 Air-Oil version

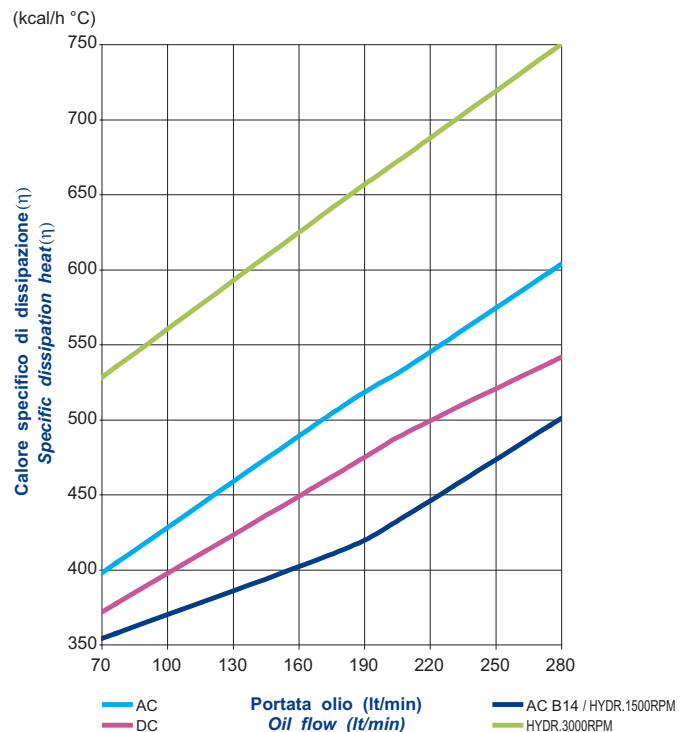
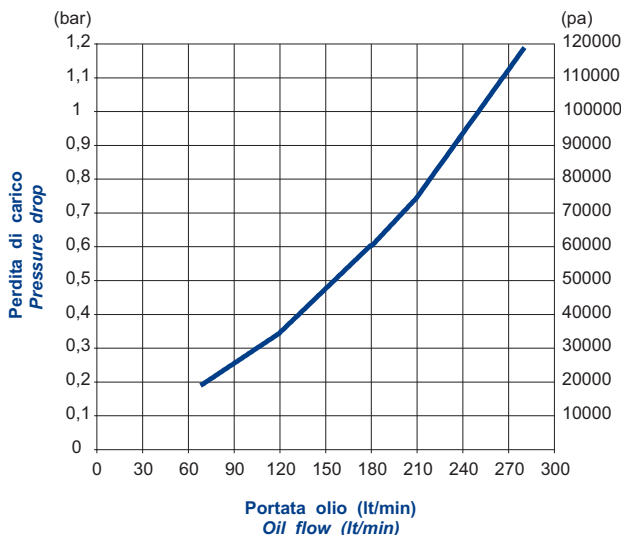

CARATTERISTICHE TECNICHE DEL GRUPPO DI VENTILAZIONE TECHNICAL FEATURES

Tipologia Type	Frequenza Frequency Hz	Tensione Voltage V	N° Giri/min RPM	Potenza Power kW	Diam. Ventola Ø FAN (mm)	dB (A)	L (mm)	Q air (m³/h)	Cap. (lt)	Peso Weight (kg)	IP
01	50/60	230	1440/1700	0.16/0.24 (x2)	400	71	223	8000	5.3	42	44
03	50/60	400	1450/1690	0.13/0.18 (x2)	400	71	223	8000	5.3	42	44
14	50/60	230/400	1430	0.55 (x2)	400	71	446	8000	5.3	50	55
12	DC	12	2500	0.200 (x2)	385	69	229	7000	5.3	41	65
24	DC	24	2500	0.200 (x2)	385	71	229	7000	5.3	41	65
G2	-	-	-	-	400	-	248	-	5.3	39	-

Portata olio consigliata da 80 a 300 (lt/min)
Suggested oil flow from 80 to 300 (lt/min)

(x2) = doppio motore
(x2) = double engine

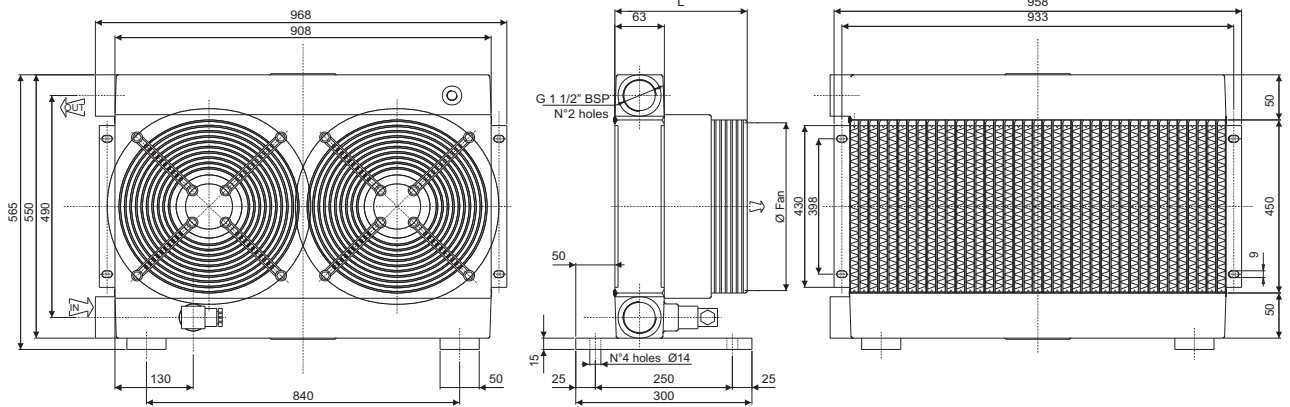

Coefficiente di correzione Correction factor

CST	10	15	20	32	40	50	60	80	100	200
F	0.51	0.66	0.76	1	1.22	1.4	1.6	1.9	2.1	3.4

Diagramma di rendimento Performance diagram

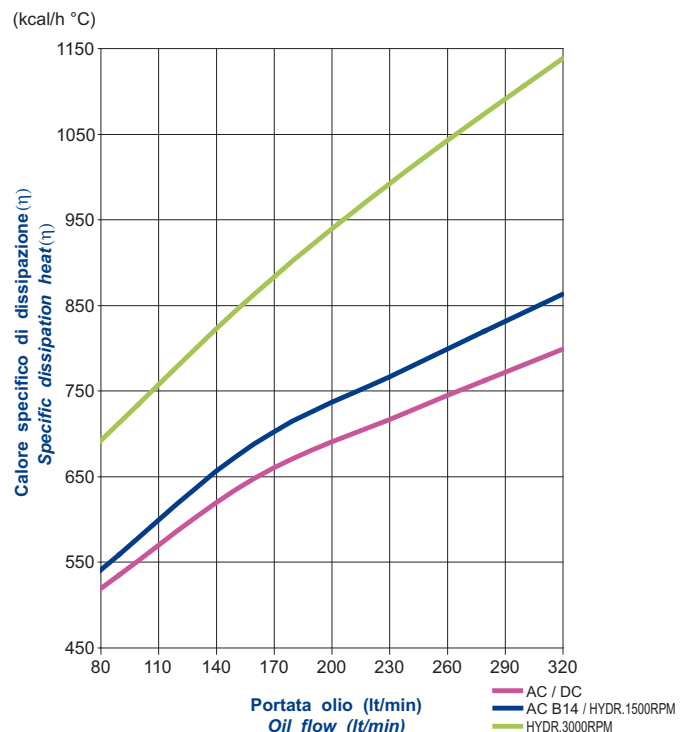

Diagramma perdite di carico (32 cst) Pressure drop diagram (32 cst)

